

Variable Attenuators & Phase Shifters



MCE
WEINSCHTEL









General Information

In this section of the catalog, each Manual Step/Variable Attenuator and Phase Shifter is outlined utilizing individual data sheets containing product features, specifications, and outline drawings. These data sheets are preceded by a quick reference guide to help you select the Manual Step/Variable Attenuator and Phase Shifter(s) that fits your needs. The page number for each Step Attenuator data sheet is given in the quick reference guide.

Continuous Variable Attenuators...dc-4.2 GHz

Model Number	Connector Type	Frequency Range (GHz)	Average Power (Watts)	Peak Power (Watts)	Residual Insertion Loss (dB)	Maximum Attenuation Range (dB)	Maximum SWR	Page No.	
940-60 940-114	SMA/N SMA/N	dc-4.0 dc-2.0	5	500	6	60 114	1.80 1.60	111	





Phase Shifters...dc to 20 GHz

Model Number	Connector Type	Frequency Range (GHz)	Incremental Phase Shift (Minimum)	Insertion Phase (Typical)	Average Power (Watts)	Maximum Insertion Loss (dB)	Maximum SWR	Page No.	
917	2.92mm	dc to 20.0	225° @ 20 GHz, 100° at 9 GHz.	890° @ 10 GHz	200	0.8	1.50	125	
980-1 980-1K	SMA	dc to 3.0	140° @ 3.0 GHz	560° @ 3.0 GHz	10	0.7-1.2*	1.30	123	
980-2 980-2K	SMA	dc to 3.0	340° @ 3.0 GHz	780° @ 3.0 GHz	10	1.0-1.7*	1.35		
980-3 980-3K	SMA	dc to 7.0	85° @ 3.0 GHz 170° @ 7.0 GHz	700° @ 3.0 GHz	10	0.5	1.30		
980-4 980-4K	SMA	dc to 12.4	290° @ 12.0 GHz	1200° @ 12.0 GHz	10	1.0	1.45		
981	3.5mm	dc to 18.0	60° /GHz	---	50	0.5-6.8*	1.80	126	

* Varies with frequency.



Manual Step Attenuators...dc-2/4/12.4/18/26.5 GHz

Model Number	Connector Type	Frequency Range (GHz)	Incremental Attenuation Range (dB)	Insertion Loss (dB)	Average Power (Watts)	Peak Power (Watts)	Maximum SWR	Page No.	
3003 3006 3007 3010 3014 3053 3054 <i>(New)</i>	SMA	dc-2.50 dc-1.25 dc-2.5 dc-2.5 dc-1.25 dc-6.0 dc-6.0	0-70/10 0-100/10 0-10/1 0-70/1 0-110/1 0-10/1 0-70/1	0.3 0.2 0.3 0.7 0.5 0.3-0.7* 0.8-1.3*	1	100	1.20 1.20 1.30 1.35 1.30 1.3-1.4* 1.3-1.55*	114	
3033	SMA	dc-2 GHz	0-10/1	0.15-0.30*	1	100	1.20-1.35*	113	
AC9009 AC9003 AC9004 AC9010 AC9011 AF9009 AF9003 AF9004 AF9010 AF9011	SMA SMA	dc-4.0 dc-18.0	0-9/1 0-69/1 0-99/1 0-60/10 0-90/10 0-9/1 0-69/1 0-99/1 0-60/10 0-90/10	0.3 0.6 0.6 0.4 0.5 0.3-1.0* 0.6-1.5* 0.6-1.5* 0.4-1.0* 0.5-1.0*	2 2	200 200	1.25 1.35 1.35 1.35 1.35 1.60 1.75 1.75 1.60 1.60	116	
9012-9 9012-70 9015-9 <i>(NEW)</i>	2.92mm 2.92mm	dc-26.5 dc-40.0	0-9/1 0-70/10 0-9/1	0.4 1.0 or 2% 0.5-1.25*	2	200	1.45-1.70* 1.50-1.70*	122	
AC115A AC116A AC117A AC118A AC119A AF115A AF116A AF117A AF118A AF119A	SMA/N TNC SMA/N TNC	dc-4.0 dc-18.0	0-9/1 0-60/10 0-69/1 0-90/10 0-99/1 0-9/1 0-60/10 0-69/1 0-90/10 0-99/1	0.3 0.3-0.4** 0.5-0.6** 0.4-0.5** 0.5-0.6** 0.7-1.0** 0.7-1.0** 1.2-1.5** 0.8-1.02** 1.2-15**	2 2	200 200	1.25 or 1.30** 1.25 or 1.30** 1.35 1.25 or 1.30** 1.25 or 1.35** 1.60 1.60 1.70 1.60 1.70	119	

Notes:

*Varies with frequency.

**Dependent on connector type.



Frequently Asked Questions about Variable/Step Attenuators & Phase Shifters....

What are the applications for Weinschel's variable/manual step attenuators?

Continuously Variable Attenuators are used in applications where the need exists for controlling signal levels continuously without interrupting the circuit. Most Weinschel models are in linear scales, and have low frequency sensitivity with broad frequency coverage, resulting from the use of proven Weinschel Corporation resistive films. The resistive elements located in these Variable Attenuators provide long-term stability over temperature and humidity.



Manual Step Attenuators are primarily used in areas demanding broadband accuracy with low SWR and accurate repeatability over large attenuation ranges. The Weinschel Step Attenuators utilize the excellent performance characteristics of the Weinschel fixed coaxial attenuators. The Weinschel step attenuators are widely used in many types of ATE and OEM systems operating throughout the world.

Weinschel Corporation offers a selection of different attenuation ranges and frequency ranges to select from. These range from 0 to 10 dB in 1 dB steps up to 0 to 100 dB in 10 dB steps and frequency ranges from dc to 40 GHz. High volume fabrication techniques, including injection molding, stamping, broaching and thick film printing ensure a cost effective and uniform product.

What is the difference between insertion loss and incremental attenuation?

Step and variable attenuators have insertion loss and also incremental attenuation. Insertion loss is the loss through the attenuator when all cells are switched to zero dB. It is the residual loss of the device itself. Insertion loss usually increases with frequency reaching several dB at the higher frequencies and generally has very flat frequency response. Incremental attenuation is the attenuation values of the attenuators cells relative to the insertion loss. Since insertion loss is always present, the performance of a step or variable attenuator is always given as incremental attenuation relative to insertion loss. Insertion loss is considered part of the fixed performance of the system path in which the step or variable attenuator is located.

What types of variable attenuators does Weinschel offer?

There are several designs of continuously variable attenuator available: Piston, card, tee, and resistive center conductor. Weinschel offers only the Variable Card Attenuator Design.



Weinschel's 940 series uses a card resistor on a disk with a movable coaxial contact (shown below) similar in nature to a potentiometer and provides an incremental range of 114 dB incremental range at 2 GHz and 60 dB at 4 GHz. Because the shunt film is connected to ground permanently, in order to achieve the extended attenuation range, the minimum loss of this type attenuator is higher (4 to 6 dB).

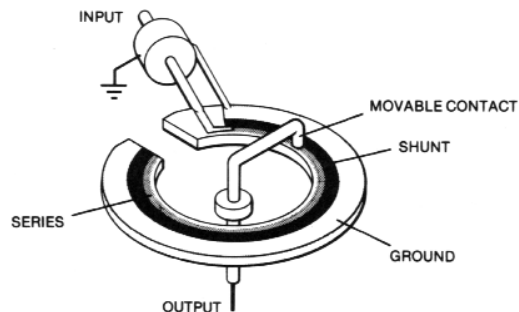



Model 940-60
Model 940-114
Precision Continuously Variable Attenuator

dc to 4.0 GHz
dc to 2.0 GHz
5 Watts

Choice of SMA or Type N Connectors



Features

- /// **Wide Variable Attenuation Range** - Variable attenuation range of 60 dB for Model 940-60 and 114 dB for Model 940-114, with minimum insertion loss at 6 dB.
- /// **Approximately Linear Calibrated Dial** - Direct reading dial individually calibrated in approximately linear 1 dB increments from 6 dB to full scale.
- /// **Rugged** - Designed to meet the environmental requirements of MIL-A-24215.
- /// **Long Life** - These variable attenuators offer a cycle life of up to 10,000 cycles. Optional models are also available to extend the life to 50,000 cycles.

Specifications

NOMINAL IMPEDANCE: 50 Ω

FREQUENCY RANGE: Model 940-60: dc to 4.0 GHz
 Model 940-114: dc to 2.0 GHz

INCREMENTAL ATTENUATION RANGE:

Model 940-60: 60 dB
 Model 940-114: 114 dB

MAXIMUM SWR:

Frequency Range (GHz)	SWR
dc - 1	1.50
1 - 2	1.60
2 - 3	1.70
3 - 4	1.80

CHARACTERISTIC INSERTION LOSS, RESIDUAL:

6 dB nominal

DIAL CALIBRATION (in 1 dB increments):

Model 940-60: 6 to 66 dB
 Model 940-114: 6 to 120 dB

DIAL INCREMENTS: 1 dB

DIRECT READING DIAL ACCURACY:

Model	ACCURACY*
940-60-XX 940-114-XX	± 0.25 dB or 0.4% @ 2 GHz ± 0.25 dB or 0.4% @ 1 GHz
940-60-XX-1 940-114-XX-1	± 0.5 dB or 1% @ 2 GHz ± 0.5 dB or 1% @ 1 GHz

*Whichever is greater.

RESOLUTION OF SCALE:

Model 940-60: ~ 115°
 Model 940-114: ~ 270°

CYCLE LIFE: A cycle consists of a rotation from minimum to maximum and back to minimum

Model 940-XX-XX : 10,000
 Model 940-XX-XX-1: 50,000

PHASE SHIFT WITH CHANGE IN ATTENUATION:

1° per dB x f(GHz) maximum

POWER RATING: 5 watts average to 40°C ambient temperature, derated linearly to 0 watts @ 85°C. 500 watts peak (5 μsec pulse width; 0.5% duty cycle).

POWER COEFFICIENT: < 0.005 dB/dB/watt

TEMPERATURE COEFFICIENT: <0.001 dB/dB/°C

TEMPERATURE RANGE:

Operating: 0°C to +85°C
 Nonoperating: -55°C to +125°C.

FREQUENCY SENSITIVITY:

Model 940-60: 0.05 x A x (F - Fd) dB
 Model 940-114: 0.1 x A x (F - Fd) dB

A = Attenuation setting in dB, Fd = Dial cut frequency in GHz, F= Operation frequency in GHz

CALIBRATION: Calibration frequency for Model 940-60 is 2 GHz and 1 GHz for 940-114. Test data is available at additional cost.

CONNECTOR: SMA or Type N connector per MIL-STD-348 interface dimensions - mate nondestructively with MIL-C-39012 connector.

Connector Options	INPUT (J1)	OUTPUT (J2)
11	SMA, Female	SMA, Female
12	SMA, Female	SMA, Male
22	SMA, Male	SMA, Male
33	N, Female	N, Female
34	N, Female	N, Male
44	N, Male	N, Male

CONSTRUCTION: Aluminum body and stainless steel connector; gold plated beryllium copper contacts. Knob is included with each unit.

WEIGHT: Net 1,570 g (3 lbs, 8 oz)

MODEL NUMBER DESCRIPTION:

Example:

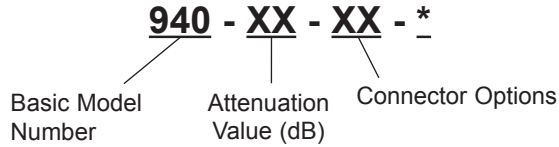

*Add -1 for long life version.

ACCESSORIES

ATTENUATOR STAND, MODEL 940 Z: This stand allows a user to easily mount any Model 940 for those bench applications.

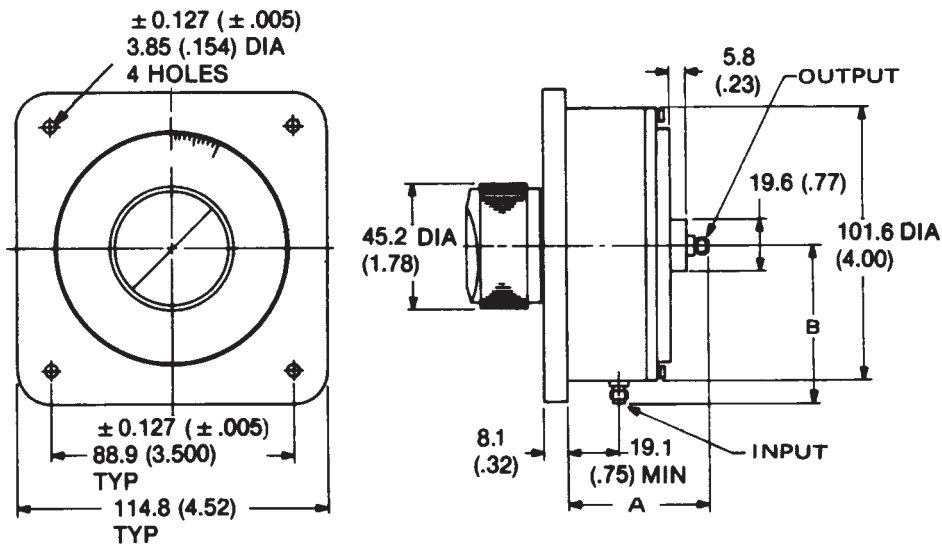
PHYSICAL DIMENSIONS:

Model No.	DIM A	DIM B
940-XX-11	52.3 (2.06)	58.2 (2.29)
940-XX-12	55.6 (2.19)	58.2 (2.29)
940-XX-22	55.6 (2.19)	61.5 (2.42)
940-XX-33	61.0 (2.40)	68.1 (2.68)
940-XX-34	66.0 (2.60)	68.1 (2.68)
940-XX-44	66.0 (2.60)	71.9 (2.83)

NOTE: All dimensions are given in mm (inches) and are maximum, unless otherwise specified.

Model 3033 RF Manual Step Attenuators

**dc to 2.0 GHz
1 Watts**

SMA Connector



Features

- /// **Make-Before Break Contacts** - Prevents signal loss during switching.
- /// **Cost Effective Design** - Optimized for Wireless Communication System Applications.
- /// **Ruggedized Connector** - Injection molded to provide consistent interface dimensions.
- /// **Custom Designs Available.**

Specifications

NOMINAL IMPEDANCE: 50 Ω

FREQUENCY RANGE: dc to 2.0 GHz

INCREMENTAL ATTENUATION RANGE/STEPS:

Model 3033: 0-10 dB in 1.0 dB steps

TEMPERATURE RANGE: -20 °C to +85 °C

POWER RATING: 1 watt **average** @ 25°C ambient temperature, derated linearly to 0.25 watt @ 85°C. 100 watts **peak** (5 μsec pulse width; 0.5 % duty cycle).

PHYSICAL DIMENSIONS:

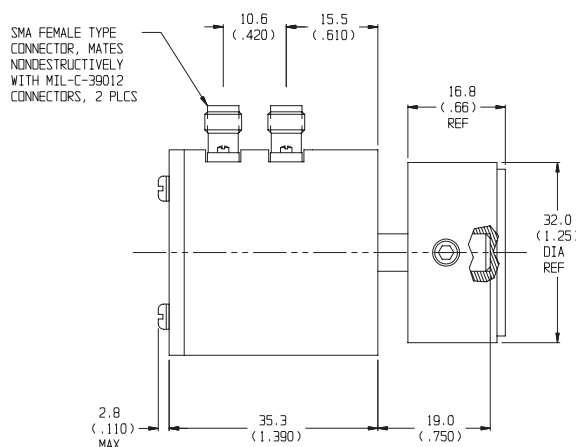

ATTENUATION ACCURACY (dB):

Frequency (GHz)	Accuracy
dc - 1.0	± 0.20 dB
1.0 - 2.0	± 0.40 dB

CONNECTOR: SMA female connector per MIL-STD-348 interface dimensions - mate nondestructively with MIL-C-39012 connector.

SHAFT ROTATION: Clockwise for increasing attenuation

STEP ANGLE: 30.0°

MAXIMUM SWR & INSERTION LOSS:

Frequency (GHz)	SWR	Loss (dB)
dc-1.0	1.20	0.15
1.0-2.0	1.35	0.30

DRUM CONFIGURATIONS: Single Drum

ROTATION STOPS: Supplied on all models.

INCREMENTAL PHASE SHIFT: 22° maximum @ 2 GHz (10° typical)

CONSTRUCTION: Machined aluminum body, Stainless steel connector; gold plated beryllium copper contacts. Knob is included with each unit.

WEIGHT: Net 110 g (4 oz)

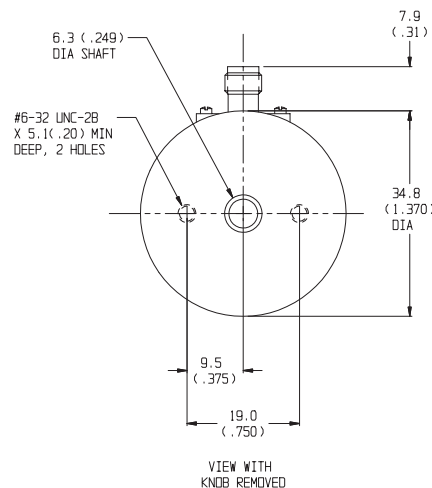

NOTE: All dimensions are given in mm (inches) and are maximum, unless otherwise specified.



Model 3003, 3006, 3007, 3010, & 3014
Model 3053 & 3054
Manual Step Attenuators

dc to 1.5/2.5 GHz
dc to 6.0 GHz
1 Watt



Rugged SMA Connector



Features

- /// **New Models** - Models 3053 & 3054 offer an extended frequency range to 6 GHz.
- /// **High Reliability** - Repeatability better than 0.1 dB over frequency range and life. Weinschel patented detent mechanism, tested to 1,000,000 operations at +75°C, operates dependably even down to -40°C.
- /// **Product Uniformity** - High volume fabrication techniques, including injection molding, stamping, broaching and thick film printing ensure a cost effective and uniform product.
- /// **Low Frequency Sensitivity** - Typically 0.1 to 0.2 dB up to 2.5 GHz.
- /// **Shock Resistant** - 100% spring contact system withstands mechanical and thermal shock and eliminates the need for epoxy or solder.
- /// **Wide Selection** - Wide choice of attenuation ranges and increments in standard stock models. Single and dual drum configurations available.
- /// **Knob Included** - Knobs for both single and dual drum models are included with every attenuator. Characters are screened on the face of the knob insert which is coated with a clear layer of epoxy for protection.

Special Configurations

Some modifications to the basic configuration of the 3000 Series can be made during manufacturing. Examples of these special configurations are shafts having special lengths and ends; clockwise shaft rotation; modified mounting arrangements; and provisions for add-on items such as concentric potentiometer and ganged switches.

Specifications

NOMINAL IMPEDANCE: 50 Ω
FREQUENCY RANGE: FREQUENCY RANGE:
 Models 3006, 3014: dc to 1.25 GHz
 Models 3003, 3007, 3010: dc to 2.5 GHz
 Models 3053, 3054: dc to 6.0 GHz
INCREMENTAL ATTENUATION RANGE/STEPS:
 Model 3003: 0-70 dB in 10 dB steps
 Model 3006: 0-100 dB in 10 dB steps
 Model 3007: 0-10 dB in 1 dB steps
 Model 3010: 0-70 dB in 1 dB steps
 Model 3014: 0-110 dB in 1 dB steps
 Model 3053: 0-10 dB in 1 dB steps
 Model 3054: 0-70 dB in 1 dB steps

POWER COEFFICIENT: < 0.006 dB/dB/watt
TEMPERATURE COEFFICIENT: 0.0004 dB/dB/ °C
TEMPERATURE RANGE:

Operating: -40°C to +65°C
 Non-Operating: -54°C to +85°C

POWER RATING: 1 watts **average** @ 25°C ambient temperature, derated linearly to 0 watts @ 65°C. 100 watts **peak** (5 μsec pulse width; 0.5 % duty cycle).

ATTENUATION ACCURACY:

Model	Accuracy
3003	± 0.3 dB or 1% up to 60 dB ± 2% to 70 dB
3006	± 0.3 dB or 1% up to 60 dB ± 2% to 100 dB
3007, 3053	± 0.3 dB
3010	± 0.3 dB up to 10 dB ± 0.3 dB or 1.5% to 60 dB ± 2 % to 70 dB
3014	± 0.3 dB up to 10 dB ± 0.3 dB or 1.5% to 60 dB ± 2% to 110 dB
3054	± 0.3 dB or 2% (dc to 3 GHz) ± 0.3 dB or 3.5% (3 to 6 GHz)

CONNECTOR: SMA female connector per MIL-STD-348 interface dimensions - mate nondestructively with MIL-C-39012 connector.

SHAFT ROTATION: counter clockwise for increasing attenuation

STEP ANGLE: 32.7°

DRUM CONFIGURATIONS:

Single Drum: 3003, 3006, 3007, 3053
 Dual Drum: 3010, 3014, 3054



Specifications-Con't

MAXIMUM SWR & ZERO INSERTION LOSS:			
Model	Frequency (GHz)	SWR	Loss (dB)
3003	dc - 2.5	1.20	< 0.3
3006	dc - 1.5	1.20	< 0.2
3007	dc - 2.5	1.30	< 0.3
3010	dc - 1.5	1.35	< 0.7
3014	dc - 1.5	1.30	< 0.5
3053	dc - 3.0	1.30	< 0.3
	3.0 - 6.0	1.40	< 0.7
3054	dc - 3.0	1.30	< 0.8
	3.0 - 6.0	1.55	< 1.3

SWITCHING LIFE: 1,000,000 steps
REPEATABILITY: ±0.1 dB over frequency range and rated life
ROTATION STOPS: Supplied on 10 dB step drums (not supplied on 1 dB drums).
INCREMENTAL PHASE SHIFT: ~0.25° per dB x f(GHz)
CONSTRUCTION: Shafting and external hardware and connector shells: CRES Type 303, per ASTM-A582 passivated per QQ-P-35. Housing: AL ALLOY Gold Flash. Knob is included with each unit.
CALIBRATION: Test data is available at additional cost.
WEIGHT: Single drum: Net 125 g (4.4 oz)
Dual drum: Net 201 g (9.9 oz)

MODEL NUMBER DESCRIPTION:

Example:

3010 - 100

Basic Model Number

Additional Options no longer available. Add -100 Only!

PHYSICAL DIMENSIONS:

SINGLE DRUM

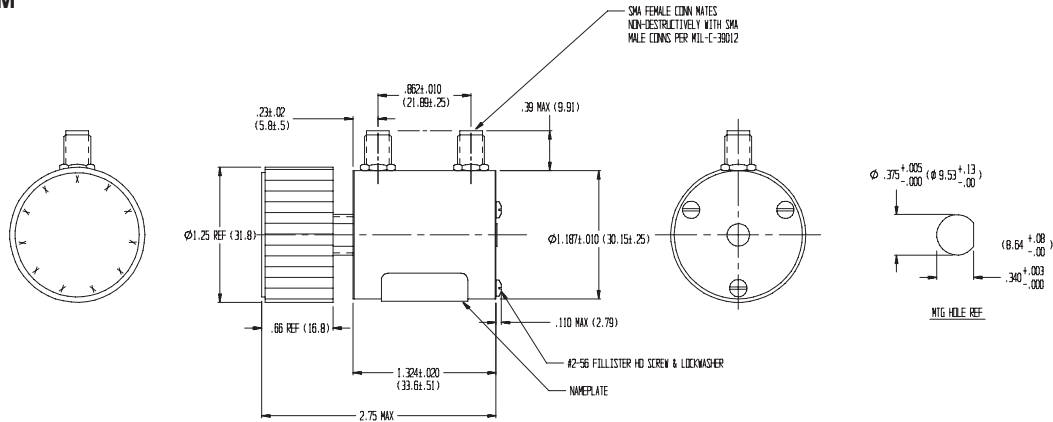

DUAL DRUM

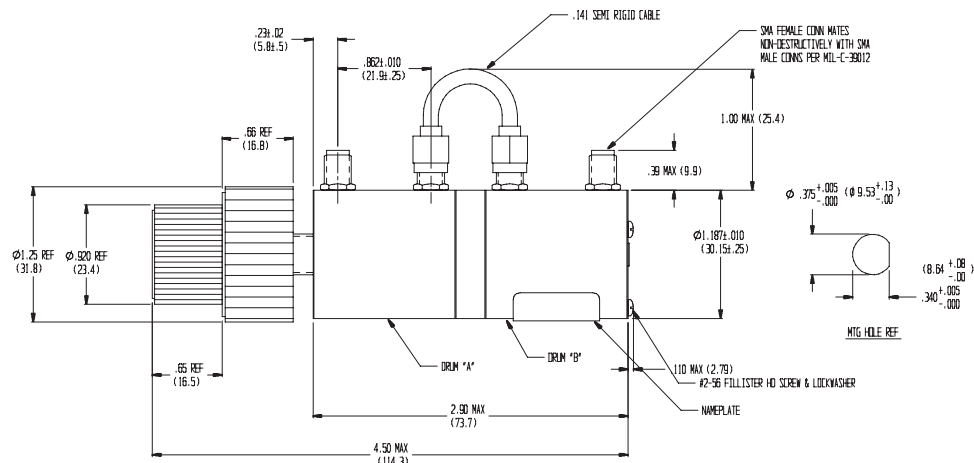



Model 9003, 9004, 9009, 9010, & 9011 Manual Step Attenuators

**dc to 18.0 GHz
2 Watt**

Ruggedized SMA Connector



Features

- /// **Broadband** - Available in a choice of frequency ranges: dc to 4, dc to 8, dc to 12.4 and dc to 18 GHz.
- /// **Wide Choice of Attenuation Ranges** - A choice of five standard attenuation ranges is available: 0 to 9.0, 0 to 69 and 0 to 99 dB in 1 dB steps, and 0 to 60 and 0 to 90 dB in 10 dB steps.
- /// **Environmental** - Designed to meet most environmental requirements of MIL-A-24215 (Vibration, Shock, Relative Humidity to 95% and Altitude).
- /// **In-line Configuration** - Passivated stainless steel SMA connector are set parallel with control shaft (except units with right angle connector) to reduce volume for applications where space is critical. All models are bidirectional.
- /// **Precise Incremental Attenuation Accuracy** - Model 9000 series has flat frequency response and small deviation from nominal attenuation at all settings (e.g., deviation is only ± 2.5 dB at 99 dB setting at 18 GHz).
- /// **Excellent Repeatability and Long Switch Life.**
- /// **Custom Configurations Available Upon Request.**
- /// **Highly Accurate Detent Stepping** - Direct drive of attenuator drums eliminates gears and provides for excellent repeatability.
- /// **Safety Mechanical Stop** - A mechanical stop between maximum and 0 attenuation positions on all models except 0-9 dB unit is provided to prevent large power changes at attenuator output from damaging sensitive equipment.

Description

The Model 9000 series Step Attenuators are broadband miniature step attenuators that provide excellent performance characteristics suitable for use in high reliability 50 ohm systems and applications requiring extra-small components for the precision control of signal levels. The Model 9000 series can be used either as input or output attenuators in signal sources, receivers, field strength meters, spectrum analyzers, etc.

The SMA connector furnished on all models are available in either standard or right-angle configuration. The sex of front and rear connector is optional (refer to connector specification for specific combinations available). A knob(s), marked appropriately, is supplied with each unit.

Specifications

NOMINAL IMPEDANCE: 50 Ω

FREQUENCY RANGE (add Model No. Prefix to Designate Range):

All Models: dc to 4.0 GHz (AC)
 dc to 18.0 GHz (AF)

Standard Incremental Attenuation Range:

Model 9009: 0 to 9 dB in 1 dB steps
Model 9003: 0 to 69 dB in 1 dB steps
Model 9004: 0 to 99 dB in 1 dB steps
Model 9010: 0 to 60 dB in 10 dB steps
Model 9011: 0 to 90 dB in 10 dB steps

MAXIMUM SWR:

Frequency Range (GHz)	9009, 9010 9011	9003 9004
dc - 4	1.25	1.35
dc - 18	1.60	1.75

POWER RATING: 2 watts **average** to 25°C ambient temperature, derated linearly to 1 watt @ 54°C. 200 watts **peak** (5 μ sec pulse width; 0.5% duty cycle)

POWER COEFFICIENT: < 0.005dB/dB/watt

TEMPERATURE COEFFICIENT: < 0.0004 dB/dB/°C

TEMPERATURE RANGE:

Operating: 0°C to + 54°C
Nonoperating: -54°C to +54°C



Specifications--con't

CALIBRATION: Insertion Loss data is supplied as follows. Other test data can be supplied at additional cost.

dc to 4 GHz: At 50 MHz and 4 GHz
 dc to 18 GHz: At 50 MHz, 4, 8, 12 and 18 GHz

INCREMENTAL PHASE SHIFT: ~0.5° per dB per GHz

REPEATABILITY: Better than 0.05 dB across frequency band for switch life

SWITCH LIFE: Over 1,000,000 steps

SHAFT ROTATION: Clockwise for increasing attenuation.

CONSTRUCTION:

Drum Assembly: Aluminum alloy
 Housing: Phenolic or aluminum
 Control Shaft: Stainless steel
 Connector: Stainless steel
 Knob: Supplied with control knob

INDEXING: 36°

DRUM CONFIGURATIONS:

Single Drum: 9009, 9010, 9011
 Dual Drum: 9003, 9004

MAXIMUM INSERTION LOSS (dB):

Frequency Range (GHz)	Model No.				
	9009	9003	9004	9010	9011
dc - 4	0.3	0.6	0.6	0.4	0.5
4 - 8	0.5	0.8	0.8	0.5	0.6
8 - 12.4	0.7	1.0	1.0	0.7	0.7
12.4 - 18	1.0	1.5	1.5	1.0	1.0

CONNECTOR: SMA connector per MIL-STD-348 interface dimensions - mate nondestructively with MIL-C-39012 connector. Front and rear SMA connector available in either standard or right-angle configuration, connector sex is optional as follows:

Connector Options	Type/Description
1	SMA, Female
2	SMA, Male*
3	SMA, Female, right-angle
4	SMA, Male, right-angle

*Standard male SMA connector not available as J1 connector.

WEIGHT:

9009	680 g (2.4 oz)
9010	160 g (5.7 oz)
9011	200 g (7.1 oz)
9003	260 g (9.0 oz)
9004	290 g (10.4 oz)

INCREMENTAL INSERTION LOSS (±dB):

Model Number	dB Range	Frequency Range (GHz)	
		dc-4	dc-18
9009	1-9	0.3	0.5
9003	1-9	0.3	0.5
	10-19	0.7	1.0
	20-29	0.9	1.2
	30-39	1.0	1.4
	40-49	1.1	1.5
	50-59	1.2	1.7
9004	60-69	1.3	1.9
	1-9	0.3	0.5
	10-19	0.7	1.0
	20-29	0.9	1.2
	30-39	1.0	1.4
	40-49	1.1	1.5
9010	50-59	1.2	1.7
	60-69	1.3	1.9
	70-79	1.4	2.1
	80-89	1.5	2.3
	90-99	1.6	2.5
	9011	10	0.3
20		0.3	1.0
30		0.4	1.0
40		0.5	1.2
50		0.7	1.5
60		0.8	1.8
9011	70	0.9	2.1
	80	1.0	2.3
	90	1.2	2.5

NA=Model no longer available.

MODEL NUMBER DESCRIPTION:

Example:

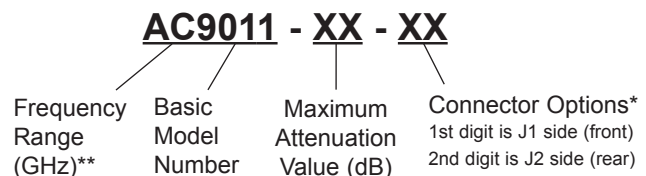

** Frequency Range

dc-4.0 GHz (AC)
 dc-8.0 GHz (AD)
 dc-12.4 GHz (AE)
 dc-18.0 GHz (AF)

Available Models

AC9003, AC9004, AC9009, AC9010, AC9011
 No longer available, order AF as replacement
 No longer available, order AF as replacement
 AF9003, AF9004, AF9009, AF9010, AF9011



PHYSICAL DIMENSIONS:

TYPICAL RIGHT ANGLE CONNECTOR

MODELS 9009, 9010, 9011

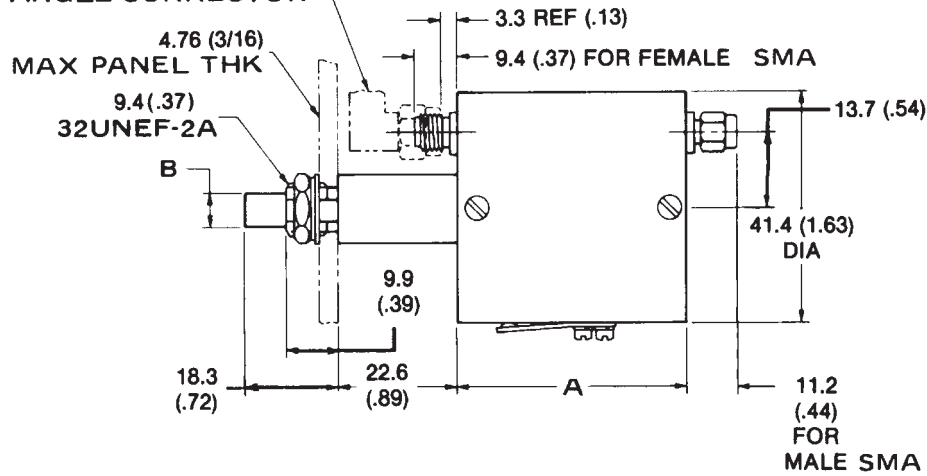

MOUNTING HOLE

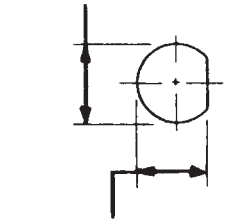
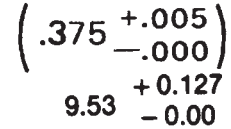

TYPICAL RIGHT ANGLE CONNECTOR

MODELS 9003, 9004

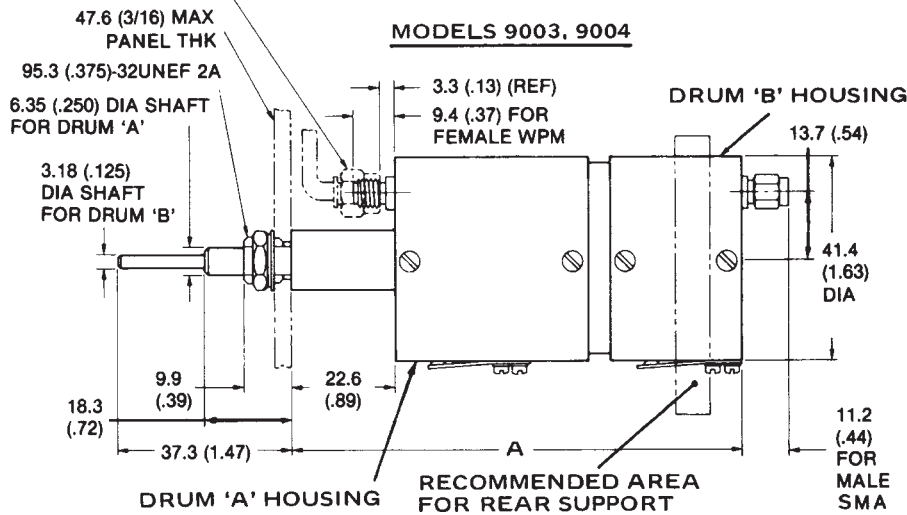

RIGHT ANGLE FEMALE SMA

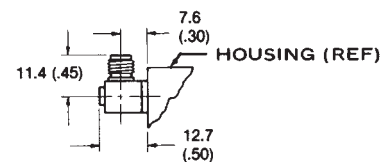

RIGHT ANGLE MALE SMA

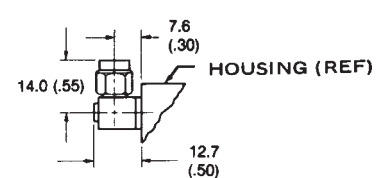

Model No.	DIM A	DIM B
9003	96.3 (3.79)	---
9004	106.4 (4.19)	---
9009	28.7 (1.13)	3.25 (0.125)
9010	41.4 (1.63)	6.35 (0.250)
9011	51.6 (2.03)	6.35 (0.250)

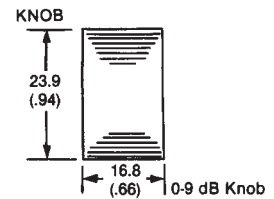
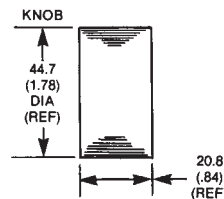

NOTE: All dimensions are given in mm (inches) and are maximum, unless otherwise specified.

Model 115A thru 119A Manual Step Attenuators

dc to 18.0 GHz
2 Watt

Choice of Type N, TNC, SMA Connector



Features

- /// **Safety Mechanical Stop** - A mechanical stop between maximum and 0 attenuation positions on all models prevents damage to the mechanical drive as well as preventing large power changes that could cause damage to sensitive equipment.
- /// **Choice of Attenuation Ranges** - Five standard attenuation ranges are available: 0-9 dB, 0-69 dB, and 0-99 dB in 1 dB steps, and 0-60 dB and 0-90 dB in 10 dB steps.
- /// **Broadband** - All models are available in a choice of 3 frequency ranges: dc-4, dc-12.4, and dc-18 GHz (dc-16 for units with TNC connector).
- /// **Right-Angle Drive** - The center conductor of the connector is perpendicular to the control shaft, offering greater flexibility of applications: panel mounting or bench setup. All models are bidirectional.
- /// **Custom Configurations Available Upon Request.**
- /// **Low Deviation from Nominal Value** - These Mini Step Attenuators have flat frequency response over specified bands and excellent attenuation accuracy. Deviation from nominal value is low at all settings.
- /// **Excellent Repeatability and Long Life Switch** - Repeatability is better than 0.05 dB to 18.0 GHz for over 1,000,000 switchings of the drum.

Description

The Weinschel Corporation Models 115A through 119A are a series of broadband, step attenuators in a right-angle drive configuration, where the center conductor of the connector is perpendicular to the control shaft. They feature excellent performance characteristics suitable for use in high reliability 50 ohm systems and applications requiring extra-small components for the precision control of power in discrete steps. They can be used either as input or output attenuators in signal sources, receivers, field strength meters, spectrum analyzers, etc.

Specifications

NOMINAL IMPEDANCE: 50 Ω

FREQUENCY RANGE (add Model No. Prefix to Designate Range):

All Models: dc to 4.0 GHz (AC)
dc to 18.0 GHz (AF)*

*dc to 16.0 GHz for TNC connector

STANDARD INCREMENTAL ATTENUATION RANGE:

Model 115A: 0 to 9 dB in 1 dB steps
Model 116A: 0 to 60 dB in 10 dB steps
Model 117A: 0 to 69 dB in 1 dB steps
Model 118A: 0 to 90 dB in 10 dB steps
Model 119A: 0 to 99 dB in 1 dB steps

MAXIMUM SWR (Models 117A & 119A):

Frequency Range (GHz)	SMA, N	TNC
dc - 4	1.35	1.35
dc - 18	1.70	1.70

MAXIMUM SWR (Models 115A, 116A, & 118A):

Frequency Range (GHz)	SMA, N	TNC
dc - 4	1.25	1.30
dc - 18	1.60	1.60

POWER RATING: 2 watts **average** to 25°C ambient temperature, derated linearly to 1 watt @ 54°C. 200 watts **peak** (5 μ sec pulse width; 0.5% duty cycle)

POWER COEFFICIENT: < 0.005/dB/dB/watt

TEMPERATURE COEFFICIENT: < 0.0004/dB/dB/°C

TEMPERATURE RANGE: Operating: 0°C to +54°C
Nonoperating: -54°C to +54°C

INCREMENTAL PHASE SHIFT: ~0.5° per dB x f(GHz)

REPEATABILITY: Better than 0.05 dB across frequency band for switch life.

SWITCH LIFE: Over 1,000,000 steps

INDEXING: 36°



Specifications (Con't):

MAXIMUM INSERTION LOSS (dB):					
Model Number	CONN Type	Frequency Range (GHz)			
		dc-4	4-8	8-12.4	dc-18*
115A	N	0.3	0.4	0.5	0.7
	SMA/TNC	0.3	0.5	0.7	1.0
116A	N	0.3	0.4	0.5	0.7
	SMA/TNC	0.4	0.5	0.7	1.0
117A	N	0.5	0.7	0.9	1.2
	SMA/TNC	0.6	0.8	1.0	1.5
118A	N	0.4	0.5	0.6	0.8
	SMA/TNC	0.5	0.6	0.7	1.0
119A	N	0.5	0.7	0.9	1.2
	SMA/TNC	0.6	0.8	1.0	1.5

*dc-16.0 GHz for TNC connector

CALIBRATION: Insertion Loss data is supplied as follows. Other test data can be supplied at additional cost.

- dc to 4 GHz: At 50 MHz and 4 GHz
- dc to 18 GHz: At 50 MHz, 4, 8, 12 and 18 GHz*

*dc-16.0 GHz with TNC units.

RELATIVE HUMIDITY: 95%

ALTITUDE: to 10,000 ft.

SHOCK (non-operating): 8 g's, 100 ms, 1/2 sine

DRUM CONFIGURATIONS:

- Single Drum: 115A, 116A, 118A
- Dual Drum: 117A, 119A

VIBRATION (non-operating):

- 5 to 8 cps, 0.20 inch double amplitude
- 8 to 15 cps, 0.10 inch double amplitude
- 15 to 55 cps, 0.36 inch double amplitude
- Supported rigidly front and back

SHAFT ROTATION: Clockwise for increasing attenuation

CONSTRUCTION:

- Materials: Housing: aluminum alloy, clear irridite, MIL-C-5541.
- Dust Cover: Painted aluminum alloy
- Drum: Aluminum alloy
- Shaft: Passivated stainless steel
- Connector: Stainless steel and beryllium copper contacts.

CONNECTOR: SMA connector per MIL-STD-348 interface dimensions - mate nondestructively with MIL-C-39012 connector. Front and rear SMA connector available in either standard or right-angle configuration, connector sex is optional as follows:

Connector Options	Type/Description
1	SMA, Female
2	SMA, Male
3	Type N, Female
4	Type N, Male
6	TNC, Female
7	TNC, Male

INCREMENTAL INSERTION LOSS (±dB):			
Model Number	dB Range	Frequency Range (GHz)	
		dc-4	dc-18*
115A	1-9	0.3	0.5
117A	1-9	0.3	0.5
	10-19	0.7	1.0
	20-29	0.9	1.2
	30-39	1.0	1.4
	40-49	1.1	1.5
	50-59	1.2	1.7
119A	60-69	1.3	1.9
	1-9	0.3	0.5
	10-19	0.7	1.0
	20-29	0.9	1.2
	30-39	1.0	1.4
	40-49	1.1	1.5
116A	50-59	1.2	1.7
	60-69	1.3	1.9
	70-79	1.4	2.1
	80-89	1.5	2.3
	90-99	1.6	2.5
	10	0.3	1.0
118A	20	0.3	1.0
	30	0.4	1.0
	40	0.5	1.2
	50	0.7	1.5
	60	0.8	1.8
	70	0.9	2.1
119A	80	1.0	2.3
	90	1.2	2.5

*dc to 16.0 GHz for TNC connector

WEIGHT:	Model	Weight
	115A	340 g (12 oz)
	116A	340 g (12 oz)
	117A	760 g (27 oz)
	118A	450 g (16 oz)
	119A	880 g (31 oz)

MODEL NUMBER DESCRIPTION:

Example:

AC116A - XX - XX

Frequency Range (GHz)	Basic Model Number	Maximum Attenuation Value (dB)	Connector Options* 1st digit is J1 side (front) 2nd digit is J2 side (rear)

PHYSICAL DIMENSIONS:

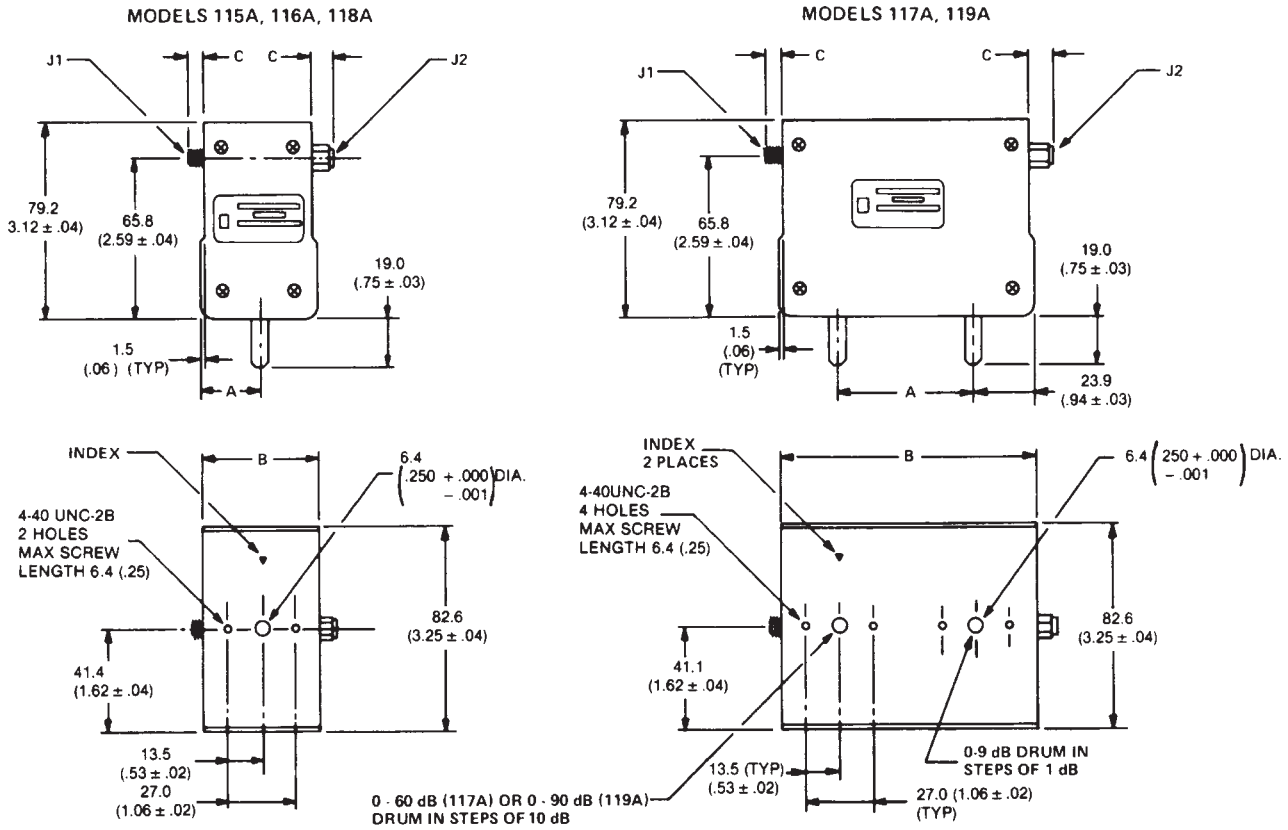

Model No.	DIM A	DIM B
119A	58.7 (2.31)	111.3 (4.38)
118A	29.0 (1.14)	57.7 (2.27)
117A	54.0 (2.11)	101.1 (3.98)
116A	23.9 (0.94)	47.5 (1.87)
115A	23.9 (0.94)	47.5 (1.87)

CONN Type	DIM C
TNC, Male	35.0 (1.38)
TNC, Female	38.1 (1.50)
Type N, Male	20.6 (0.81)
Type N, Female	18.3 (0.72)
SMA, Male	9.4 (0.37)
SMA, Female	7.9 (0.31)

NOTE: All dimensions are given in mm (inches) and are maximum, unless otherwise specified.



Model 9012 Model 9015 Manual Step Attenuators

**dc to 26.5 GHz
dc to 40 GHz
2 Watts**



2.92mm Connectors



Features

- /// Choice of Attenuation Ranges and Step Sizes.
- /// Excellent Repeatability.
- /// Custom Configurations Available Upon Request.
- /// Highly Accurate Detent Stepping
- /// Ruggedized Connector - Injection molded to provide consistent interface dimensions.

Specifications

NOMINAL IMPEDANCE: 50 Ω
FREQUENCY RANGE: Model 9012: dc to 26.5 GHz
 Model 9015: dc to 40.0 GHz
INCREMENTAL ATTENUATION RANGE/STEPS:
 Model 9012-9, 9015-9: 0-9 dB in 1 dB steps
 Model 9012-70: 0-70 dB in 10 dB steps

INCREMENTAL INSERTION LOSS (dB):	
Model No.	Accuracy
9012-9, 9015-9	± 0.5 dB
9012-70	± 1.0 dB or 2%

MAXIMUM SWR:		
Frequency Range (GHz)	9012	9015
dc - 18	1.45	1.50
18 - 26.5	1.70	1.70
26.5 - 40	---	1.70

MAXIMUM ZERO INSERTION LOSS (±dB):		
Frequency Range (GHz)	9012	9015
dc - 18	0.50	0.50
18 - 26.5	1.50	1.25
26.5 - 40	---	1.25

POWER RATING: 2 watts **average** to 25°C ambient temperature, derated linearly to 1 watt @ 54°C. 200 watts **peak** (5 μsec pulse width; 0.5% duty cycle)

POWER COEFFICIENT: < 0.005 dB/dB/watt

TEMPERATURE COEFFICIENT: < 0.0004 dB/dB/°C

TEMPERATURE RANGE:

Operating: 0°C to + 54°C
 Nonoperating: -54°C to + 54°C

CALIBRATION: Insertion loss and SWR data supplied at selected frequencies between 50 MHz and 26.5/40 GHz. Other test data can be provided at additional cost.

CONNECTOR: 2.92mm female connector - mate nondestructively with SMA connector per MIL-C-39012, 3.5mm, and other 2.92mm connector.

CONSTRUCTION: Stainless steel connector; gold plated beryllium copper contacts. Knob is included with each unit.

WEIGHT: Net 270 g (9.6 oz)

PHYSICAL DIMENSIONS:

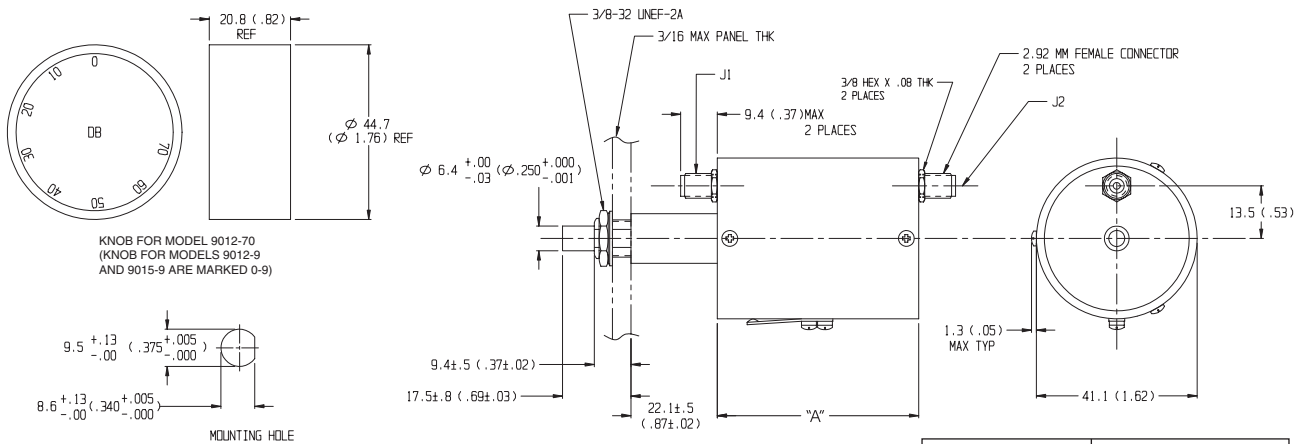

NOTE: All dimensions are given in mm (inches) and are maximum, unless otherwise specified.

Model No.	DIM A
9012-9, 9012-70	51.56 (2.03)
9015-9	50.04±.51 (1.97±.02)



Model 980 Coaxial Phase Shifters

dc to 3.0/7.0/12.0 GHz
10 Watts

Ruggedized SMA Connector



Features

- /// **Self Locking** - Internal mechanism eliminates the need for a locking nut. Ideal for phase trimming in densely packaged systems with minimum accessibility.
- /// **Linear** - Nominally linear phase over the frequency range.
- /// **Optimized for Wireless OEM Applications.**
- /// **New Models with Adjustment Knobs**
(See Models 980-1K through 980-4K).

Specifications

NOMINAL IMPEDANCE: 50 Ω

FREQUENCY RANGE:

Model 980-1 & 980-1K:	dc to 3.0 GHz
Model 980-2 & 980-2K:	dc to 3.0 GHz
Model 980-3 & 980-3K:	dc to 7.0 GHz
Model 980-4 & 980-4K:	dc to 12.0 GHz

INCREMENTAL PHASE SHIFT:

Model 980-1 & 980-1K:	140° minimum @ 3.0 GHz
Model 980-2 & 980-2K:	170° minimum @ 1.5 GHz 340° minimum @ 3.0 GHz
Model 980-3 & 980-3K:	85° minimum @ 3.5 GHz 170° minimum @ 7.0 GHz
Model 980-4 & 980-4K:	290° minimum @ 12.0 GHz

MAXIMUM INSERTION LOSS (dB):

Model No.	Frequency Range (GHz)			
	1.5	3.0	7.0	12.0
980-1 & -1K	0.70 dB	1.20 dB	---	---
980-2 & -2K	1.00 dB	1.70 dB	---	---
980-3 & -3K	0.50 dB	0.50 dB	0.50 dB	---
980-4 & -4K	1.00 dB	1.00 dB	1.00 dB	1.00 dB

INSERTION PHASE:

Model 980-1 & 980-1K:	560° (Typical) @ 3.0 GHz
Model 980-2 & 980-2K:	780° (Typical) @ 3.0 GHz
Model 980-3 & 980-3K:	700° (Typical) @ 7.0 GHz
Model 980-4 & 980-4K:	1200° (Typical) @ 12.0 GHz

PHASE VS FREQUENCY: Nominally linear response

MAXIMUM SWR:

Frequency Range (GHz)	Model No.			
	908-1/1K	980-2/2K	980-3/3K	980-4/4K
dc - 3	1.30	1.35	1.30	1.30
3 - 7	---	---	1.30	1.30
7 - 12	---	---	---	1.60

POWER RATING: 10 watts average

TEMPERATURE RANGE:

Operating:	-50°C to 85°C
Storage:	-50°C to 125°C

CONNECTOR: SMA female connector per MIL-STD-348 interface dimensions - mate nondestructively with MIL-C-39012 connector.

WEIGHT: Models 980-1 & 980-2:	50 g (1.80 oz)
Models 980-1K & 980-2K:	60 g (2.14 oz)
Model 980-3 & 980-4:	25 g (0.88 oz)
Model 980-3K & 980-4K:	35 g (1.24 oz)

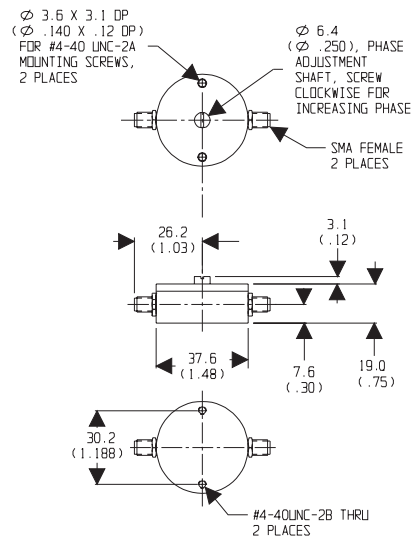
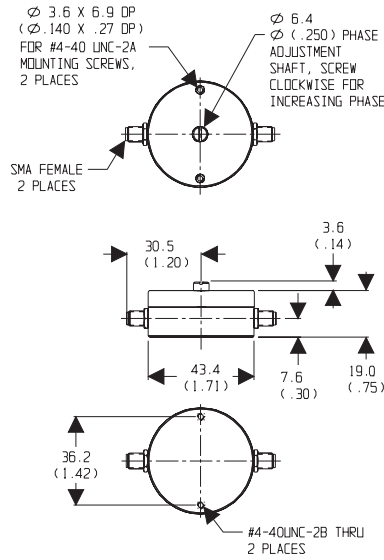
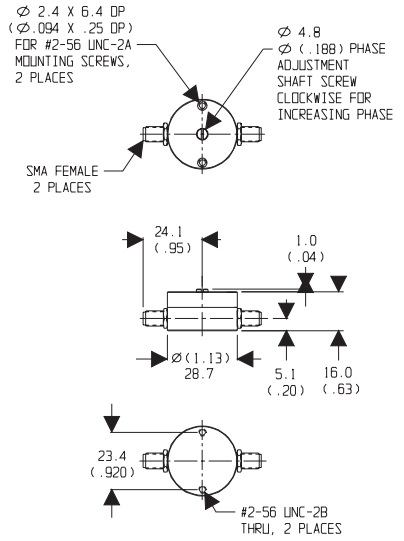
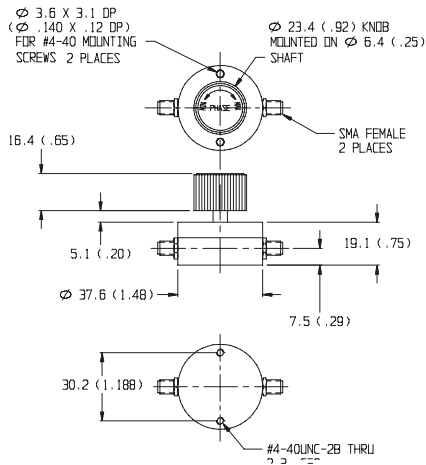
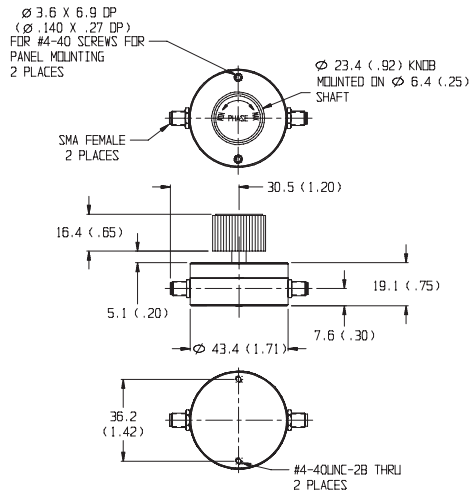
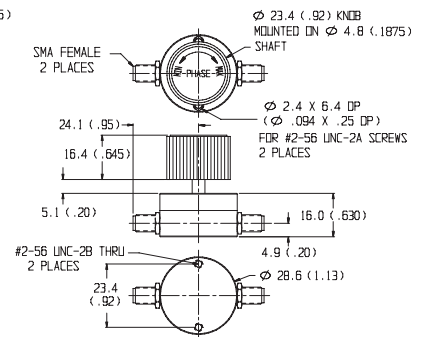
PHYSICAL DIMENSIONS:

MODEL 980-1

MODEL 980-2

MODELS 980-3 & 980-4

MODEL 980-1K

MODEL 980-2K

MODEL 980-3K & 980-4K

NOTE: All dimensions are given in mm (inches) and are maximum, unless otherwise specified.

Model 917 Miniature In-Line Phase Shifters

dc to 20.0 GHz
200 Watts

Ruggedized 2.92mm Connector



Features

- /// **Self Locking** - Internal mechanism eliminates the need for a locking nut. Ideal for phase trimming in densely packaged systems with minimum accessibility.
- /// **Linear** - Provides a linear adjustable phase shift to 20 GHz in a very small in-line coaxial package.

Specifications

- NOMINAL IMPEDANCE:** 50 Ω
- FREQUENCY RANGE:** dc to 20.0 GHz
- INCREMENTAL PHASE SHIFT:** Adjustable to 225° @ 20 GHz; 100° at 9 GHz.
- RESOLUTION:** 0.5° per turn per GHz, typical (Adjustment shaft has 20 turns for full range).
- INSERTION PHASE:** 890° @ 10 GHz (Typical)
- PHASE VS FREQUENCY:** Nominally linear response
- INSERTION LOSS:** 0.8 dB maximum (0.5 dB typical @ 20 GHz)

MAXIMUM SWR:

Frequency Range (GHz)	SWR
dc - 20	1.5

- POWER RATING:** 200 watts average
- TEMPERATURE RANGE:** -55°C to 125°C.

CONNECTOR: 2.92mm connector compatible with SMA, 3.5mm and K® connector. Available connector options are:

Connector Options	Type/Description
1	2.92mm, Female
2	2.92mm, Male

WEIGHT: 45 g (1.6 oz)

PHYSICAL DIMENSIONS:

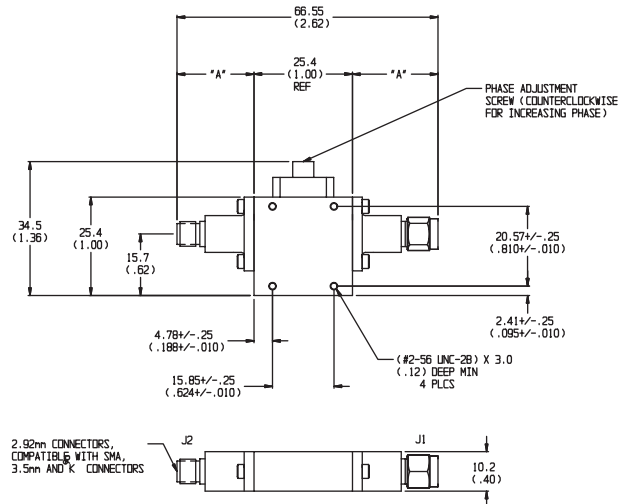

CONN TYPE	DIM A
Female	19.81 (0.78)
Male	21.34 (0.84)

NOTE:

- All dimensions are given in mm (inches) and are nominal ± 0.5 (0.02), unless otherwise specified.
- K® is a registered trademark of the Anritsu-Wiltron 2.92 mm connector.

MODEL NUMBER DESCRIPTION:

Example:

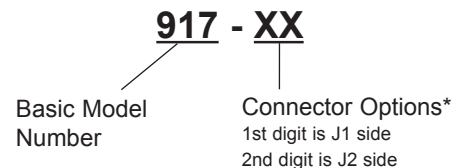



Model 981 Coaxial Phase Shifters

**dc to 18.0 GHz
50 Watts**



3.5mm Connectors



Specifications

NOMINAL IMPEDANCE: 50 Ω
FREQUENCY RANGE: dc to 18.0 GHz
INCREMENTAL PHASE SHIFT (Minimum): 60° /GHz
INSERTION LOSS (dB): 0.5 + 0.035 f(GHz)

MAXIMUM SWR:

Frequency Range (GHz)	SWR
dc - 10	1.6
10 - 18	1.8

Features

- /// **Broadband Frequency Coverage:** Operates from dc to 18 GHz, usable to 20 GHz
- /// **Ideally suited for delay line applications in optical and RF Networks.**
- /// **Easily adapts to motorized control configurations.**
- /// **Designed for long mechanical cycle life.**

POWER RATING: 50 watts average, 1 kW peak

TEMPERATURE RANGE: -50°C to 100°C.

CONNECTOR: 3.5mm female connectors compatible with 3.5mm, SMA, K® and other 2.92mm connectors.

WEIGHT: 80 g (2.84 oz)

PHYSICAL DIMENSIONS:

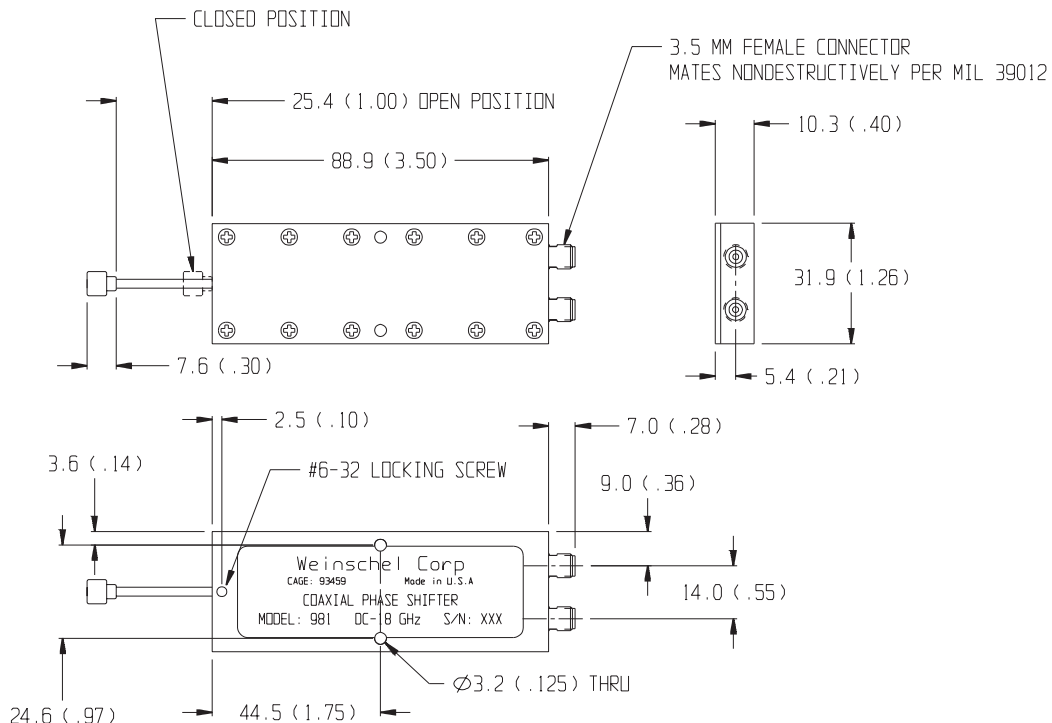

NOTE:

1. All dimensions are given in mm (inches) and are maximum unless otherwise specified.
2. K® is a registered trademark of the Anritsu 2.92 mm connector.