



Pressure Switches



Gems
Sensors

Contents

Description	Page	Vacuum Switches	20
Cross Reference Chart	4	PS81 – Ultra-Long Life Vacuum Switches	20
Introduction	5	PS82 – Economical Miniature Vacuum Switches	21
Selection Chart	6	PS83 – OEM Subminiature Vacuum Switch	22
Pressure Switches	7	Differential Switches	23
PS11 – Ultra-Long Life OEM Pressure Switches	7	PS91 – Compact Differential Switch	23
PS31 – Kapton® Diaphragm OEM Subminiature Pressure Switch	8	PS93 – General Purpose Differential Pressure Switch	24
PS32 – Elastomer Diaphragm OEM Subminiature Pressure Switch	9	Speciality Switches	25
PS41 – Economical Miniature Pressure Switches	10	PS96 – Inline Pressure Switch	25
PS51 – Kapton® Diaphragm OEM Subminiature Pressure Switch	11	PS97 – Inline Pressure Switch	25
PS52 – Elastomer Diaphragm OEM Subminiature Pressure Switch	12	PS98 – Solid State Pressure Switch	26
PS61 – OEM Subminiature Pressure Switch	13	Industrial Switches	
PS71 – General Purpose Mini Pressure Switches	14	PS-B Precision Cylindrical	27
PS75 – Rugged Cylindrical Pressure Switch	16	PC-C Industrial, High Precision	28
PS77 – Economical Industrial Pressure Switch	18	PS-C Industrial Differential	29

CONTENTS

Cross Reference Chart

PDI Series	Gems Original Part No.	Gem New Part No.	Comments
PMLF	PS-JL	PS 31/2	Low Pressure - Factory Set
PMLA	PS-JL	PS 31/2	Low Pressure - Field Adjustable
PDA	PS-E	PS 41	Low Pressure - Field Adjustable
PDF	PS-E	PS 41	Low Pressure - Factory Set
PNAP		PS 97	Low Pressure - Manifold
PIAP		PS 96	Low Pressure - Inline
PDPA		PS 11	Low Pressure - Adjustable
PDN		PS 41	Low Pressure - Field Adjustable
PDPF		PS 11	Low Pressure - Factory Set
PMMA		PS 51/2	Low Pressure - Field Adjustable
PMMF		PS 51/2	Low Pressure - Field Adjustable
PMHF	PS-J	PS 61	High Pressure - Factory Set
PMHA	PS-J	PS 61	High Pressure - Field Adjustable
PDAH	PS-EH	PS 71	High Pressure - Field Adjustable
PDFH	PS-EH	PS 71	High Pressure - Factory Set
PDCA	PS-FA	PS 75	High Pressure - Single set point
PFCA	PS-FB	PS 75	High Pressure - Factory Set
PACA	PS-FB	PS 75	High Pressure - Adjustable
CFIS	PS-K	PS 77	High Pressure
PDCM		PS 75	High Pressure - Manifold Mount
PHDA		PS 71	High Pressure - Field Adjustable
PFCM		PS 75	High Pressure - Manifold Mount
PFNM		PS 75	High Pressure - Manifold Mount
PDNM		PS 75	High Pressure - Manifold Mount
VDMF	PS-EV	PS 82	Vacuum - Factory Set
VDMA	PS-EV	PS 82	Vacuum - Field Adjustable
PDVF		PS 81	New name given to redesigned PVPF
PDVA		PS 81	New name given to redesigned PVPA
PMVF		PS 83	Vacuum - Factory Set
PMVA		PS 83	Vacuum - Field Adjustable
PJDA	PS-D	PS 93	Differential - Field Adjustable
PJDF	PS-D	PS 93	Differential - Factory Set
PDAM		PS 91	Differential - Manifold, Field Adjustable
PDDA		PS 91	Differential - Field Adjustable
		PS-98	Solid State Pressure Switch
	PS-B	PS-B	Industrial Switch
	PS-C	PS-C	Industrial Switch

The above table shows the old PDI part numbers converted to the new part numbering scheme. If there are any conversion queries, refer to www.gemssensors.com or email sales@gems-sensors.co.uk

From 2 to 6000 PSI, GEMS Pressure Switches Cover A Wide Range of Applications

- ▶ General, vacuum, differential, specialty
- ▶ Field-adjustable or factory set switches
- ▶ High proof pressure
- ▶ Rugged and dependable

GEMS offers a choice of pressure switches, from compact cylindrical models for OEM use, to larger, enclosed units for rugged process applications. These switches are ideal for the filtering process of coolants in the machine tool industry, use in transmissions of off-highway vehicles and as redundant systems with existing monitors such as transducers.



Unique Piston/Diaphragm Design

A piston/diaphragm design, incorporating the high proof pressure of piston technology allows these switches to operate with the sensitivity and accuracy of a diaphragm design. Repeatability ranges from 2 percent to 5 percent of the highest set point.

Many Materials To Choose From

Enclosures include aluminum, stainless steel, brass, reinforced plastic and zinc-plated steel. Most models are NEMA 4 or NEMA 4X certified. Wetted parts include a diaphragm available in buna-n, Teflon® coated Kapton®, stainless steel, PTFE, EPDM or Viton® and a pressure port available in stainless steel, brass, zinc or aluminum.



Pressure Switch Option Descriptions

- | | | |
|--|---|--|
| <p>G: Gold contacts are usually required for low DC current loads (<12 VDC @ 12 mA) associated with TTL input devices. They provide decreased contact resistance, which results in more reliable switching especially in the presence of an oxidizing atmosphere.</p> <p>OXY: Wetted Materials are ultrasonically cleaned per the Compressed Gas Association's Method G-4.1.</p> <p>10A: 10A option is provided by a microswitch rated 10 Amperes at 250 VAC. This microswitch has a wide movement differential, which results in a larger deadband than listed in the standard catalogue pages.</p> <p>IP: Ingress Protection is provided by either an epoxy sealed cap (IP66) or silicon wire seals (IP67). On some models, this option is only available with FS option.</p> | <p>RB: Rubber Boot is designed to be cut out for the proper wire or cable size by the customer and sealed with an appropriate sealant in the field.</p> <p>WF: Weatherpack female termination consists of the following Delphi P/N's: (12045793 Conn "C" Circuit), 12089188 Female Pins and 12015323 Wire Seals.</p> <p>WM: Weatherpack male termination consists of the following Delphi P/N's: 12010973 Connector, (12010717 Conn "C" Circuit), 12089040 Male Pins and 12015323 Wire Seals.</p> <p>DE: Deutsch male termination consists of the following Deutsch P/N's: DT04-2P Connector, (DT04-3P "C" Circuit) 1060-16-0122 Male Pins and W(2 or 3)P Wedgelok.</p> | <p>FS: Gems will preset switches to the indicated setpoint within repeatability limits listed on the specific product catalogue page.</p> <p>R: The restrictor option is recommended for hydraulic systems that need a small reduction in pressure pulsations to increase pressure switch life. It is a pressed in part that has an orifice size of 0.045"</p> <p>SR: The spiral restrictor option heavily dampens pressure pulsations in any hydraulic system, which prevents false signaling and premature wear. It is not recommended for pressure settings below 1500 psig because it slows the response time of the pressure switch.</p> |
|--|---|--|

Selection Guide

Pressure Switches

	Pressure Range	Proof Pressure	Switch	Repeatability	Notes	Series	Page
Pressure Switches	40 to 800 mbar (0.55 to 12 psi)	10 bar (150 psi)	SPST, SPDT DPST, DPDT	±2%	-	PS11	7
	0.14 to 10 bar (2 to 150 psi)	35 bar (500 psi)	SPST	±5%	Kapton® Diaphragm	PS31	8
					Elastomer Diaphragm	PS32	9
	0.2 to 7 bar (3 to 100 psi)	25 bar (350 psi)	SPST, SPDT	±2%	-	PS41	10
	1 to 20 bar (15 to 300 psi)	35 bar (500 psi)	SPST	±5%	Kapton® Diaphragm	PS51	11
					Elastomer Diaphragm	PS52	12
	0.35 to 207 bar (5 to 3000 psi)	600 bar (9000 psi)	SPST	±3%	-	PS61	13
0.7 to 344 bar (10 to 5000 psi)	600 bar (9000 psi)	SPST, SPDT	±2%	-	PS71	14	
0.35 to 414 bar (5 to 6000 psi)	600 bar (9000 psi)	SPST, SPDT DPST, DPDT	±2%	-	PS75	16	
				20 Amp Switching	PS77	18	
Vacuum Switches	25 to 508 mbar (0.75" to 15" Hg)	10 bar (150 psi)	SPST, SPDT DPST, DPDT	±2%	-	PS81	20
	169 to 1016 mbar (5" to 30" Hg)	35 bar (500 psi)	SPST, SPDT	±2%	-	PS82	21
	169 to 1016 mbar (5" to 30" Hg)	10 bar (150 psi)	SPST	±3%	-	PS83	22
Differential Switches	0.3 to 1.7 bar (5 to 25 psi)	100 bar (1500 psi)	SPDT	±2%	-	PS91	23
	0.7 to 3 bar (10 to 45 psi)	35 bar (500 psi)	SPDT	±2%	-	PS93	24
Speciality Switches	2 to 10 bar (30 to 150 psi)	100 bar (1500 psi)		±2%	-	PS96	25
					-	PS97	25
	0 to 400 bar (0 to 6000 psi)	See Specs	Relay or Transistor	.25%	Solid State	PS98	26
Industrial Switches	-1 to 540 bar (30" Hg to 7500 psi)	600 bar	SPDT	±0.5%	-	PS-B	27
	-1 to 540 bar (30" Hg to 7500 psi)	See Specs	SPDT	±0.2%	-	PS-C	28

Plastic Diaphragms

Option K or Standard Teflon® Coated Kapton® (Polyimide) Diaphragm

Teflon® is compatible with almost every liquid and gaseous media. Kapton® has very stable

physical properties over a wide temperature range -73°C to 200°C (-100°F to 400°F). This results in pressure switches that exhibit very little setpoint shift due

to temperature extremes. Kapton possesses exceptional fatigue strength but is very stiff which results in wider but more stable deadbands than most elastomers.

Elastomer Diaphragms

Elastomers offer incredible sensitivity coupled with extremely long life. This results in stable setpoints over the life of the pressure switch as well as tight deadbands. Their biggest weakness is the increase in modulus (stiffening) that occurs at lower temperatures. This results in pressure switch setpoints to shift higher and deadbands to increase with decreasing temperature. They also exhibit more hysteresis than Kapton diaphragms.

Standard: Nitrile (Buna-N). Typically specified on water and petroleum based hydraulic oils. Temperature range: 0°C to 121°C (32°F to 250°F)

Option V: Viton® (Fluorinated Hydrocarbon) Diaphragm. Typically used with alcohols, diesters, solvents, acids and synthetic oils. Also used for high vacuum service. Temperature range: 0°C to 200°C (32°F to 400°F)

Option E: EPDM (Ethylene Propylene) Diaphragm. Typically used with phosphate ester based hydraulic fluids, brake fluids, ketones, steam and hot water. Temperature range: -53°C to 100°C (-65°F to 212°F)

Option N: Neoprene (Chloroprene) Diaphragm. Typically specified for refrigerant systems. Temperature range: -53°C to 135°C (-65°F to 275°F)

Option H: ECOH (Epichlorohydrin) Diaphragm. Typically specified for petroleum based fuels and lubricants. Temperature range: -40°C to 121°C (-40°F to 250°F)

PS11 – Ultra-Long Life OEM Pressure Switches

- ▶ 40 to 800 mbar (0.55 to 12 psi)
- ▶ 1,000,000 cycle life
- ▶ Factory fixed or adjustable set points

For low pressure applications, the longevity of our PS11 Series is hard to beat. A life expectancy of 1 million cycles means long-term reliability. Their snap-action microswitch resets automatically and meets or exceeds industry standards. The brass housing offers chemical resistance at an affordable price.

Specifications

Operating Temperature	-40°C to +80°C (-40°F to +180°F)
Switch*	5 Amp at 24 VDC and 250 VAC; 0.5 Amp @ 24 VDC (-G option)
Repeatability	±2% of Full Set Point Range at 20°C (70°F) ambient temp.
Wetted Parts	
Diaphragm	Nitrile (optional Viton®, EPDM or Kapton®)
Fitting	Brass
Housing	Brass
Electrical Termination	DIN 43650A IP65; Terminals IP00; Flying Leads IP65
Proof Pressure	10 bar (150 psi)
Approvals	CE, UL Approved units available
Weight, Approximate	0.14 kg (0.31 lbs.)

*Gold contacts (option G) may be required for less than 12 VDC and 20 mA.

How to Order

Use the **bold** characters from the chart below to construct a product code.

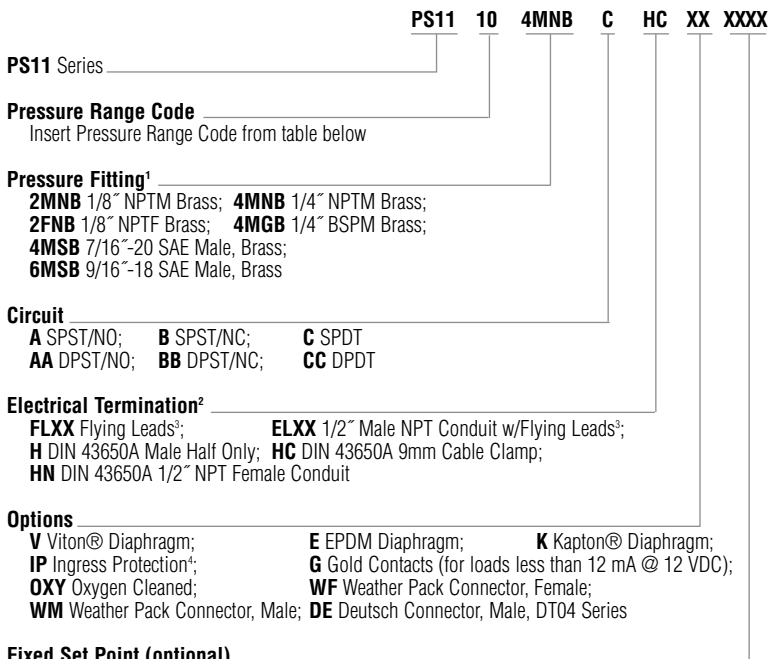

Fixed Set Point (optional)

- A. Specify set point **FS** (in PSI or mBAR, see example)⁵
 - B. Set Point Actuation
 - R** on Rising Pressure; **F** on Falling Pressure
- Example: **FS200MBARF** for 200 mBAR Falling or **FS3PSIR** for 3 PSI Rising

Notes:

- Other connectors available. Consult factory.
- DIN units are available with **C** SPDT circuit only.
- 18" is standard. Specify lead length in inches (max. 48"). e.g. **FL18** or **EL30**.
- Ingress Protection requires Fixed Set Point **FS**.
- Set Point must be within Pressure Range selected in Step 1 above.

Pressure Range Table

Pressure Range Code	Pressure Range	Average Dead Band
10	37.9-241.3 mbar (0.55-3.5 psi)	5-15 mbar (.07-02 psi)
20	206.8-827.4 mbar (3-12 psi)	20-45 mbar (.3-6 psi)



Dimensions

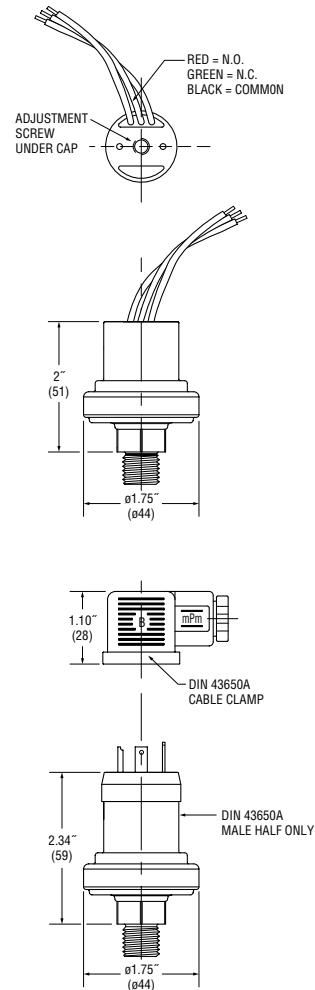

PS31 – Kapton® Diaphragm OEM Subminiature Pressure Switch

- ▶ .14 to 10 bar (2 to 150 psi) *formerly PS-JL series*
- ▶ Ideal for pneumatic and low pressure hydraulic applications
- ▶ Adjustable or factory set

These compact pressure switches are designed for OEM applications. Made economical with metal blade contacts in lieu of microswitches, the PS31 series features Kapton® diaphragms. Kapton® polyimide maintains excellent physical properties over a wide temperature range. It also offers superb chemical resistance with no known organic solvents.



Specifications

Operating Temperature	-40°C to +93°C (-40°F to +200°F)
Switch*	100 VA Max.
Repeatability	±5% of Full Set Point Range @ 20°C (70°F)
Wetted Parts	
Diaphragm	Teflon® Coated Kapton®
Fitting	Brass (optional 316 Stainless Steel)
Electrical Termination	Exposed Terminals IP00; IP option IP66
Deadband	<5% of Set Point
Proof Pressure	35 bar (500 psi)
Approvals	CE (limits switch voltage to 42 VDC)
Weight, Approximate	Brass: 0.06 kg (0.14 lbs.)

*Gold contacts (option G) may be required for less than 12 VDC and 20 mA.
Kapton® is a registered trademark of Dupont.

How to Order

Use the **bold** characters from the chart below to construct a product code.

	PS31	10	4MNB	A	SP	XX	XXXX
PS31 Series _____							
Pressure Range Code _____							
Insert Pressure Range Code from table below							
Pressure Fitting¹ _____							
<i>Brass</i>	<i>316 Stainless Steel</i>						
2MNB 1/8" NPTM	2MNS 1/8" NPTM						
4MNB 1/4" NPTM	4MNS 1/4" NPTM						
2MGB 1/8" BSPM	2MGS 1/8" BSPM						
4MGB 1/4" BSPM	4MGS 1/4" BSPM						
8MGB 1/2" BSPM	4MSS 7/16"-20 SAE Male						
M10B M10 x 1.0, Straight	6MSS 9/16"-18 SAE Male						
M12B M12 x 1.5, Straight							
4MSB 7/16"-20 SAE Male							
6MSB 9/16"-18 SAE Male							
Circuit _____							
A SPST/NO; B SPST/NC							
Electrical Termination _____							
SP Spade Terminals (standard); TS Terminal Screws; FLXX Flying Leads ² ;							
FLSXX Flying Leads w/PVC Shrink Tubing ² ; CABXX 18 AWG PVC Cable ³							
Options _____							
G Gold Contacts (for loads less than 12 mA @ 12 VDC); IP Ingress Protection ⁴ ;							
OXY Oxygen Cleaned; RB Rubber Boot (shipped loose);							
WF Weather Pack Connector, Female; WM Weather Pack Connector, Male;							
DE Deutsch Connector, Male, DT04 Series							
Fixed Set Point (optional) _____							
A. Specify set point FS (in BAR or PSI, see example) ⁵							
B. Set Point Actuation							
R on Rising Pressure; F on Falling Pressure							
Example: FS0.3BARF for 0.3 BAR Falling or FS3PSIR for 3 PSI Rising							

Notes:

- Other connectors available. Consult factory.
- 18" is standard. Specify lead length in inches (max. 48"). e.g. **FL18** or **FLS30**.
- 36" is minimum. Specify cable length in inches. e.g. **CAB36** or **CAB120**.
- Ingress Protection is available only with **FL**, **FLS** or **CAB** Electrical Termination choices.
- Set Point must be within Pressure Range selected in Step 1 above.

Pressure Range Table

Pressure Range Code	Pressure Range
10 ¹	0.14-0.7 bar (2-10 psi)
20	0.5-1.7 bar (7-25 psi)
30	1.4-4.1 bar (20-60 psi)
40	3.4-10.3 bar (50-150 psi)

- Pressure Range 10 in this model adds wetted materials Brass Spacer, 12L14 Steel Spring Guide and 302 SS Spring to the unit

PS32 – Elastomer Diaphragm OEM Subminiature Pressure Switch

- ▶ .14 to 10 bar (2 to 150 psi) *formerly PS-JL series*
- ▶ Ideal for pneumatic and low pressure hydraulic applications
- ▶ Adjustable or factory set

These compact pressure switches are designed for OEM applications. Made economical by using metal blade contacts in lieu of microswitches, the series features long-lasting Elastomer diaphragms in three materials. Elastomer diaphragms offer increased sensitivity and life for applications without temperature extremes.

Specifications

Operating Temperature	-40°C to +93°C (-40°F to +200°F)
Switch*	100 VA Max.
Repeatability	±5% of Full Set Point Range @ 20°C (70°F)
Wetted Parts	
Diaphragm	Elastomer (Nitrile standard) (Viton, EPDM optional)
Fitting	Brass standard (optional 316 SS)
Electrical Termination	Exposed Terminals IP00; IP option IP66
Deadband	<5% of Set Point
Proof Pressure	35 bar (500 psi)
Approvals	CE (limits switch voltage to 42 VDC)
Weight, Approximate	Brass: 0.06 kg (0.14 lbs.)

*Gold contacts (option G) may be required for less than 12 VDC and 20 mA.

How to Order

Use the **bold** characters from the chart below to construct a product code.

PS32 10 4MNB A SP XX XXXX

PS32 Series _____

Pressure Range Code _____
Insert Pressure Range Code from table below

Pressure Fitting¹ _____

Brass	316 Stainless Steel
2MNB 1/8" NPTM	2MNS 1/8" NPTM
4MNB 1/4" NPTM	4MNS 1/4" NPTM
2MGB 1/8" BSPM	2MGS 1/8" BSPM
4MGB 1/4" BSPM	4MGS 1/4" BSPM
4MSB 7/16"-20 SAE Male	4MSS 7/16"-20 SAE Male

Circuit _____
A SPST/NO; **B** SPST/NC

Electrical Termination _____
SP Spade Terminals (standard); **TS** Terminal Screws; **FLXX** Flying Leads²;
FLSXX Flying Leads w/PVC Shrink Tubing²; **CABXX** 18 AWG PVC Cable³

Options _____
V Viton® Diaphragm; **E** EPDM Diaphragm; **H** ECOH Diaphragm;
G Gold Contacts (for loads less than 12 mA @ 12 VDC); **IP** Ingress Protection⁴;
OXY Oxygen Cleaned; **RB** Rubber Boot (shipped loose);
WF Weather Pack Connector, Female; **WM** Weather Pack Connector, Male;
DE Deutsch Connector, Male, DT04 Series

Fixed Set Point (optional) _____
A. Specify set point **FS** (in PSI or BAR, see example)⁵
B. Set Point Actuation _____
R on Rising Pressure; **F** on Falling Pressure
Example: **FS0.3BARF** for 0.3 BAR Falling or **FS3PSIR** for 3 PSI Rising

Notes:

- Other connectors available. Consult factory.
- 18" is standard. Specify lead length in inches (max. 48"). e.g. **FL18** or **FLS30**.
- 36" is minimum. Specify cable length in inches. e.g. **CAB36** or **CAB120**.
- Ingress Protection is available only with **FL**, **FLS** or **CAB** Electrical Termination choices.
- Set Point must be within Pressure Range selected in Step 1 above.



Dimensions

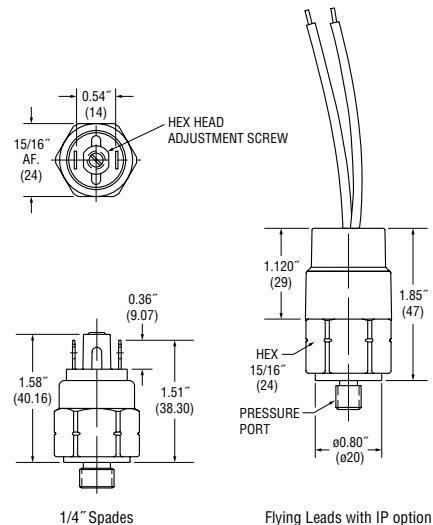

Pressure Range Table

Pressure Range Code	Pressure Range
10 ¹	0.14-0.7 bar (2-10 psi)
20	0.5-1.7 bar (7-25 psi)
30	1.4-4.1 bar (20-60 psi)
40	3.4-10.3 bar (50-150 psi)

- Pressure Range 10 in this model adds wetted materials Brass Spacer, 12L14 Steel Spring Guide and 302 SS Spring to the unit

PS41 – Economical Miniature Pressure Switches

► 0.2 to 7 bar (3 to 100 psi) – formerly PS-E series

These miniature pressure switches are designed for demanding applications where space and/or price are strong concerns. The switches utilize a piston/diaphragm design, which incorporates the high proof pressure of piston technology with the sensitivity of diaphragm designs. Switches are field adjustable via an Allen head screw that is hidden to protect against unauthorized tampering.

Specifications

Operating Temperature	-40°C to +80°C (-40°F to +180°F)
Switch*	5 Amp at 12/24 VDC and 125/250 VAC (optional 10 Amp or 1 Amp Gold Contacts)
Repeatability	±2% of Full Set Point Range @ 20°C (70°F)
Wetted Parts	
Diaphragm Material	Nitrile (optional EPDM and Viton®)
Fitting	Brass (optional 316 Stainless Steel)
Electrical Termination	DIN 43650A IP65; Terminals IP00; Flying Leads IP65; Option 20/20A IP67
Proof Pressure	25 bar (350 psi)
Approvals	CE, UL Approved units available
Weight, Approximate	0.14 kg (0.3 lbs.)

*Gold contacts (option G) may be required for less than 12 VDC and 20 mA. Viton® is a registered trademark of Dupont.

How to Order

Use the **bold** characters from the chart below to construct a product code.

PS41 10 4MNB C H XX XXXX

PS41 Series _____

Pressure Range Code _____
Insert Pressure Range Code from table below

Pressure Fitting¹ _____

Brass	316 Stainless Steel
2MNB 1/8" NPTM	2MNS 1/8" NPTM
4MNB 1/4" NPTM	4MNS 1/4" NPTM
2MGB 1/8" BSPM	4MGS 1/4" BSPM
4MGB 1/4" BSPM	
4MSB 7/16"-20 SAE Male	
6MSB 9/16"-18 SAE Male	

Circuit _____

A SPST/NO2; **B** SPST/NC2; **C** SPDT

Electrical Termination _____

SP Spade Terminals³; **FLXX** Flying Leads⁴;
FLSXX Flying Leads w/PVC Shrink Tubing⁴;
ELXX 1/2" NPT Male Conduit w/Flying Leads⁵; **CABXX** 18 AWG PVC Cable⁶;
H DIN 43650A Male Half Only; **HR** Right Angle DIN 43650A Male Half Only;
HC DIN 43650A 9mm Cable Clamp;
HCR Right Angle DIN 43650A 9mm Cable Clamp;
HN DIN 43650A with 1/2" Female NPT Conduit;
HNR Right Angle DIN 43650A with 1/2" Female NPT Conduit;
HM Micro (9.4mm Spacing) DIN Style Male Half Only

Options⁷

V Viton Diaphragm; **N** Neoprene Diaphragm; **E** EPDM Diaphragm;
10A 10A @ 125/250 VAC Max. Rating;
G Gold Contacts (for loads less than 12 mA @ 12 VDC);
RD Reduced Differential (50% reduction typical); **IP** Ingress Protection²;
OXY Oxygen Cleaned; **WF** Weather Pack Connector, Female;
WM Weather Pack Connector, Male; **DE** Deutsch Connector, Male, DT04 Series

Fixed Set Point (optional) _____

A. Specify set point **FS** (in BAR or PSI, see example)⁸
B. Set Point Actuation
R on Rising Pressure; **F** on Falling Pressure
Example: **FS0.5BARF** for 0.5 BAR Falling or **FS5PSIR** for 5 PSI Rising

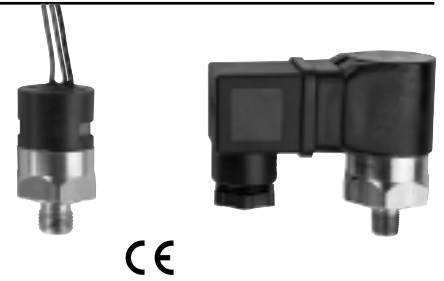

Dimensions

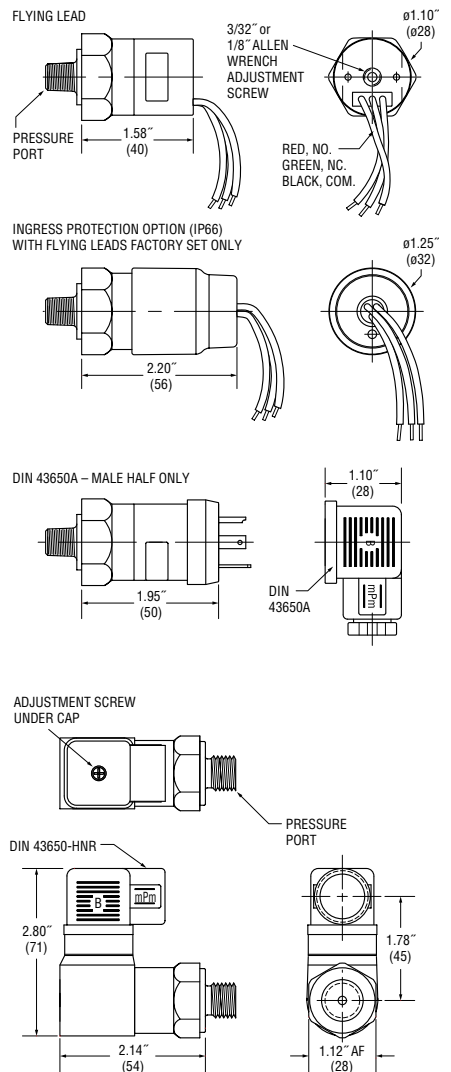

Pressure Range Table

Pressure Range Code	Pressure Range	Average Dead Band
10	0.2-0.5 bar (0.3-7 psi)	0.07-0.14 bar (1-2 psi)
20	0.35-2.1 bar (5-30 psi)	0.14-0.28 bar (2-4 psi)
30	1.7-6.9 bar (25-100 psi)	0.21-0.85 bar (3-12 psi)

PS51 – Kapton® Diaphragm OEM Subminiature Pressure Switch

- ▶ 1 to 20 bar (15 to 300 psi)
- ▶ Adjustable or factory set

These compact pressure switches are designed for OEM applications. This economical design uses metal blade contacts in lieu of microswitches and features Kapton® diaphragms. Kapton® polyimide maintains excellent physical properties over a wide temperature range. It also offers superb chemical resistance with no known organic solvents.



Specifications

Operating Temperature	-40°C to +93°C (-40°F to +200°F)
Switch*	100 VA Max.
Repeatability	±5% of Full Set Point Range @ 20°C (70°F)
Wetted Parts	
Diaphragm	Teflon® Coated Kapton®
Fitting	Brass standard (optional 316 SS)
Electrical Termination	Exposed Terminals IP00; IP option IP66
Deadband	<5% of Set Point
Proof Pressure	35 bar (500 psi)
Approvals	CE (limits switch voltage to 42 VDC)
Weight, Approximate	Brass: 0.06 kg (0.14 lbs.)

*Gold contacts (option G) may be required for less than 12 VDC and 20 mA.
Kapton® is a registered trademark of Dupont.

How to Order

Use the **bold** characters from the chart below to construct a product code.

	PS51	10	4MNB	A	SP	XX	XXXX
PS51 Series	_____						
Pressure Range Code	_____						
Insert Pressure Range Code from table below							
Pressure Fitting¹	_____						
Brass	316 Stainless Steel						
2MNB 1/8" NPTM	2MNS 1/8" NPTM						
4MNB 1/4" NPTM	4MNS 1/4" NPTM						
2MGB 1/8" BSPM	2MGS 1/8" BSPM						
4MGB 1/4" BSPM	4MGS 1/4" BSPM						
8MGB 1/2" BSPM	4MSS 7/16"-20 SAE Male						
M10B M10 x 1.0, Straight	6MSS 9/16"-18 SAE Male						
M12B M12 x 1.5, Straight							
4MSB 7/16"-20 SAE Male							
6MSB 9/16"-18 SAE Male							
Circuit	_____						
A SPST/NO; B SPST/NC							
Electrical Termination	_____						
SP Spade Terminals (standard); TS Terminal Screws; FLXX Flying Leads ² ;							
FLSXX Flying Leads w/PVC Shrink Tubing ² ; -CABXX 18 AWG PVC Cable ³							
Options	_____						
G Gold Contacts (for loads less than 12 mA @ 12 VDC); IP Ingress Protection ⁴ ;							
OXY Oxygen Cleaned; -RB Rubber Boot (shipped loose);							
WF Weather Pack Connector, Female; WM Weather Pack Connector, Male;							
DE Deutsch Connector, Male, DT04 Series							
Fixed Set Point (optional)	_____						
A. Specify set point FS (in BAR or PSI, see example) ⁵							
B. Set Point Actuation							
R on Rising Pressure; F on Falling Pressure							
Example: FS5BARF for 5 BAR Falling or FS20PSIR for 20 PSI Rising							

Dimensions

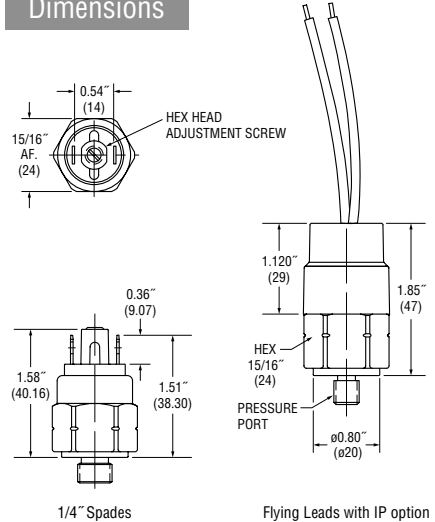

Pressure Range Table

Pressure Range Code	Pressure Range
10	1.0-10.3 bar (15-150 psi)
20	10.3-20.7 bar (150-300 psi)

Notes:

- Other connectors available. Consult factory.
- 18" is standard. Specify lead length in inches (max. 48"). e.g. **FL18** or **FLS30**.
- 36" is minimum. Specify cable length in inches. e.g. **CAB36** or **CAB120**.
- Ingress Protection is available only with **FL**, **FLS** or **CAB** Electrical Termination choices.
- Set Point must be within Pressure Range selected in Step 1 above.

PS52 – Elastomer Diaphragm OEM Subminiature Pressure Switch

- ▶ 1 to 20 bar (15 to 300 psi)
- ▶ Adjustable or factory set

These compact pressure switches are designed for OEM applications. Designed to be economical by using metal blade contacts in lieu of microswitches they feature long-lasting Elastomer diaphragms. Elastomer diaphragms offer increased sensitivity and life for applications without temperature extremes.

Specifications

Operating Temperature	-40°C to +93°C (-40°F to +200°F)
Switch*	100 VA Max.
Repeatability	±5% of Full Set Point Range @ 20°C (70°F)
Wetted Parts	
Diaphragm	Nitrile (optional EPDM and Viton®)
Fitting	Brass (optional 316 Stainless Steel)
Electrical Termination	Exposed Terminals IP00; IP option IP66
Deadband	<5% of Set Point
Proof Pressure	35 bar (500 psi)
Approvals	CE (limits switch voltage to 42 VDC)
Weight, Approximate	Brass: 0.06 kg (0.14 lbs.)

*Gold contacts (option G) may be required for less than 12 VDC and 20 mA.
Kapton® is a registered trademark of Dupont.

How to Order

PS52 10 4MNB A SP XX XXXX

Pressure Range Code _____
Insert Pressure Range Code from table below right

Pressure Fitting¹ _____

<i>Brass</i>	<i>316 Stainless Steel</i>
2MNB 1/8" NPTM	2MNS 1/8" NPTM
4MNB 1/4" NPTM	4MNS 1/4" NPTM
2MGB 1/8" BSPM	2MGS 1/8" BSPM
4MGB 1/4" BSPM	4MGS 1/4" BSPM
4MSB 7/16"-20 SAE Male	4MSS 7/16"-20 SAE Male

Circuit _____
A SPST/NO; **B** SPST/NC

Electrical Termination _____
SP Spade Terminals (standard); **TS** Terminal Screws; **FLXX** Flying Leads²;
FLSXX Flying Leads w/PVC Shrink Tubing²; **CABXX** 18 AWG PVC Cable³

Options _____
V Viton® Diaphragm; **E** EPDM Diaphragm; **H** ECOH Diaphragm;
G Gold Contacts (for loads less than 12 mA @ 12 VDC); **IP** Ingress Protection⁴;
OXY Oxygen Cleaned; **RB** Rubber Boot (shipped loose);
WF Weather Pack Connector, Female; **WM** Weather Pack Connector, Male;
DE Deutsch Connector, Male, DT04 Series

Fixed Set Point (optional)
A. Specify set point **FS** (in BAR or PSI, see example)⁵ _____
B. Set Point Actuation _____
R on Rising Pressure; **F** on Falling Pressure
Example: **FS5BARF** for 5 BAR Falling or **FS20PSIR** for 20 PSI Rising

Notes:

- Other connectors available. Consult factory.
- 18" is standard. Specify lead length in inches (max. 48"). e.g. **FL18** or **FLS30**.
- 36" is minimum. Specify cable length in inches. e.g. **CAB36** or **CAB120**.
- Ingress Protection is available only with **FL**, **FLS** or **CAB** Electrical Termination choices.
- Set Point must be within Pressure Range selected in Step 1 above.



Dimensions

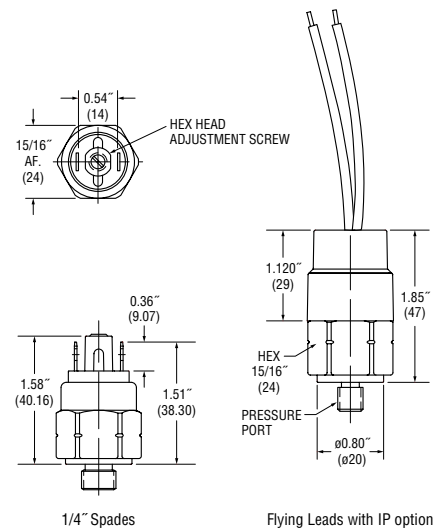

1/4" Spades

Flying Leads with IP option

Pressure Range Table

Pressure Range Code	Pressure Range
10	1.0-10.3 bar (15-150 psi)
20	10.3-20.7 bar (150-300 psi)

PS61 – OEM Subminiature Pressure Switch

- ▶ .35 to 207 bar (5 to 3000 psi) *formerly PS-J series*
- ▶ Exceptional size-to-pressure-range ratio
- ▶ Adjustable or factory set

These compact pressure switches are designed for OEM applications. They are equipped with high proof pressure capabilities for demanding hydraulic applications such as forklifts, scissor lifts, and off road equipment.

Specifications

Operating Temperature	-40°C to +93°C (-40°F to +200°F)
Switch*	100 VA Max.
Repeatability	±3% of Full Set Point Range @ 20°C (70°F)
Wetted Parts	
Diaphragm	Nitrile (optional Neoprene, EPDM or Viton®)
Fitting	Zinc Plated Steel (optional 316 Stainless Steel)
Electrical Termination	Exposed Terminals IP00; IP option IP66
Deadband	<5% of Set Point
Proof Pressure	600 bar (9000 psi)
Approvals	CE (limits switch voltage to 42 VDC)
Weight, Approximate	Brass: 0.06 kg (0.14 lbs.)

*Gold contacts (option G) may be required for less than 12 VDC and 20 mA.
Kapton® and Viton® are registered trademarks of Dupont.

How to Order

PS61 10 4MNZ A SP XX XXX

Pressure Range Code

Insert Pressure Range Code from table below right

Pressure Fitting¹

12L14 Zinc Plated Steel	316 Stainless Steel
2MNZ 1/8" NPTM	2MNS 1/8" NPTM
4MNZ 1/4" NPTM	4MNS 1/4" NPTM
2MGZ 1/8" BSPM	2MGS 1/8" BSPM
4MGZ 1/4" BSPM	4MGS 1/4" BSPM
4MSZ 7/16"-20 SAE Male	4MSS 7/16"-20 SAE Male
6MSZ 9/16"-18 SAE Male	6MSS 9/16"-18 SAE Male
8MGZ 1/2" BSPM	
M10Z M10 x 1.0, Straight	
M12Z M12 x 1.5, Straight	

Circuit

A SPST/NO; B SPST/NC

Electrical Termination

SP Spade Terminals (standard); TS Terminal Screws; FLXX Flying Leads²;
FLSXX Flying Leads w/PVC Shrink Tubing²; CABXX 18 AWG PVC Cable²

Options

V Viton® Diaphragm; E EPDM Diaphragm; N Neoprene Diaphragm;
H ECOH Diaphragm; G Gold Contacts (for loads less than 12 mA @ 12 VDC);
IP Ingress Protection⁴; R Restrictor (low damping coefficient) Brass;
SR Spiral Restrictor (high damping coefficient) 12L14 Steel w/Black Oxide Finish;
OXY Oxygen Cleaned; RB Rubber Boot (shipped loose);
WF Weather Pack Connector, Female; WM Weather Pack Connector, Male;
DE Deutsch Connector, Male, DT04 Series

Fixed Set Point (optional)

A. Specify set point **FS** (in BAR or PSI, see example)⁵
B. Set Point Actuation

R on Rising Pressure; F on Falling Pressure

Example: **FS3BARF** for 3 BAR Falling or **FS60PSIR** for 60 PSI Rising

Notes:

- Other connectors available. Consult factory.
- 18" is standard. Specify lead length in inches (max. 48"). e.g. **FL18** or **FLS30**.
- 36" is minimum. Specify cable length in inches. e.g. **CAB36** or **CAB120**.
- Ingress Protection is available only with **FL**, **FLS** or **CAB** Electrical Termination choices and requires Fixed Set Point (**FS**).
- Set Point must be within Pressure Range selected in Step 1 above.



Dimensions

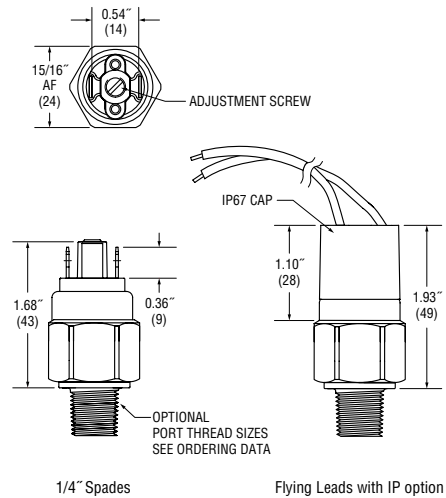

Pressure Range Table

Pressure Range Code	Adjustment Ranges
11	1-4 bar (15-60 psi)
15	2.7-10.3 bar (40-150 psi)
20	6.9-34.5 bar (100-500 psi)
30	20.7-50.0 bar (300-725 psi)
40	34.5-86.2 bar (500-1250 psi)
50	69.0-206.8 bar (1000-3000 psi)

PS71 – General Purpose Mini Pressure Switches

▶ .7 to 344 bar (10 to 5000 psi) *formerly PS-EH series*

These versatile general purpose switches with snap action microswitches can be used in a wide range of hydraulic and pneumatic applications. Their proven piston/diaphragm design offers outstanding accuracy over a very wide pressure range with an outstanding 9000 psi proof pressure. Their modular construction allows Gems to offer a large number of standard pressure fittings in two materials as well as numerous electrical ratings and terminations. Users can easily configure this model to meet their needs.

Specifications

Operating Temperature	-40°C to +80°C (-40°F to +180°F)
Switch*	5 Amp at 12/24 VDC and 125/250 VAC (Optional 10 Amp or 1 Amp with Gold contacts)
Repeatability	±2% of Full Set Point Range @ 20°C (70°F)
Wetted Parts	
Diaphragm	Nitrile (optional EPDM, Viton® or Neoprene)
Fitting	Zinc Plated Steel (Optional 316 SS)
Electrical Termination	DIN 43650A IP65; Spade Terminals IP00; Flying Leads IP65; Conduit with Flying Leads IP00; IP option IP66
Proof Pressure	600 bar (9000 psi)
Approvals	CE, UL Approved units available
Weight, Approximate	0.15 kg (0.4 lbs.)

*Gold contacts (option G) may be required for less than 12 VDC and 20 mA.
Viton® is a registered trademark of Dupont.



Dimensions

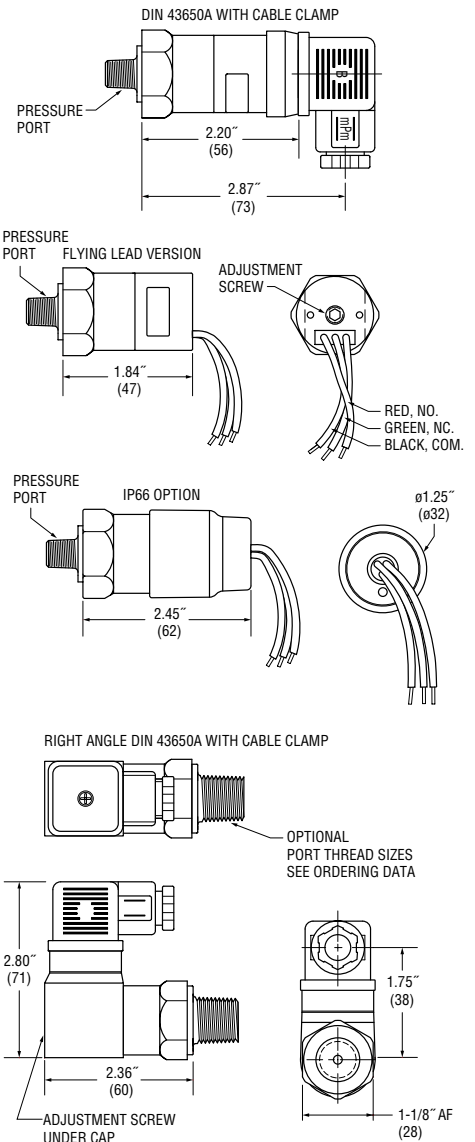

How to Order

Use the **Bold** characters from the chart below to construct a product code.

PS71 10 4MNZ C H XX XXXX

Pressure Range Code

Insert Pressure Range Code from table below

Pressure Fitting¹

<i>12L14 Zinc Plated Steel</i>	<i>316 Stainless Steel</i>
2MNZ 1/8" NPTM	2MGS 1/8" BSPM
4MNZ 1/4" NPTM	4MNS 1/4" NPTM
2MGZ 1/8" BSPM	4MGS 1/4" BSPM
4MGZ 1/4" BSPM	
4MSZ 7/16"-20 SAE Male	
6MSZ 9/16"-18 SAE Male	

Circuit

A SPST/NO; **B** SPST/NC; **C** SPDT

Electrical Termination

SP Spade Terminals²; **FLXX** Flying Leads²;
FLSXX Flying Leads w/PVC Shrink Tubing²;
ELXX 1/2" NPT Male Conduit w/Flying Leads⁴; **CABXX** 18 AWG PVC Cable²;
H DIN 43650A Male Half Only⁶; **HR** Right Angle DIN 43650A Male Half Only⁶;
HC DIN 43650A 9mm Cable Clamp⁶;
HCR Right Angle DIN 43650A 9mm Cable Clamp⁶;
HN DIN 43650A with 1/2" Female NPT Conduit⁶;
HNR Right Angle DIN 43650A with 1/2" Female NPT Conduit⁶;
HM Micro (9.4mm Spacing) DIN Style Male Half Only⁶

Options⁷

V Viton® Diaphragm; **E** EPDM Diaphragm; **N** Neoprene Diaphragm;
10A 10A @ 125/250 VAC Max. Rating;
G Gold Contacts (for loads less than 12 mA @ 12 VDC);
RD Reduced Differential (50% reduction typical); **IP** Ingress Protection⁸;
OXY Oxygen Cleaned⁹; **R** Restrictor (low damping coefficient) Brass;
SR Spiral Restrictor (high damping coefficient) 12L14 Steel w/Black Oxide Finish;
WF Weather Pack Connector, Female; **WM** Weather Pack Connector, Male;
DE Deutsch Connector, Male, DT04 Series

Fixed Set Point (optional)

- A. Specify set point **FS** (in BAR or PSI, see example)¹⁰
 B. Set Point Actuation

R on Rising Pressure; **F** on Falling Pressure

Example: **FS2BARF** for 2 BAR Falling or **FS20PSIR** for 20 PSI Rising

Notes:

- Other connectors available. Consult factory.
- Requires **10A** or **G** option.
- 18" is standard. Specify lead length in inches (max. 48"). e.g. **FL18** or **FLS30**.
- 18" is standard. Specify cable length in inches (max. 48"). e.g. **EL18** or **EL30**.
- 36" is minimum. Specify cable length in inches. e.g. **CAB36** or **CAB120**.
- DIN connectors require **C** SPDT circuit.
- Options **10A**, **G** or **RD** cannot be combined.
- Ingress Protection is available only with **FL**, **FLS** or **CAB** Electrical Termination choices. Ingress Protection requires Fixed Set Point **FS**.
- Requires stainless steel housing.
- Set Point must be within Pressure Range selected in Step 1 above.

Pressure Range Table

Pressure Range Code	Adjustment Ranges	Average Dead Band
10	0.7-2.1 bar (10-30 psi)	0.25-0.40 bar (4-6 psi)
20	1.7-5.2 bar (25-75 psi)	0.35-0.65 bar (5-10 psi)
30	4.5-20.7 bar (65-300 psi)	1.3-2.6 bar (20-40 psi)
40	17.2-69 bar (250-1000 psi)	2.6-5.7 bar (40-85 psi)
50	69-206.8 bar (1000-3000 psi)	8-15 bar (120-220 psi)
60	172.4-344.7 bar (2500-5000 psi)	21-35 bar (300-500 psi)

How to Order

Use the **Bold** characters from the chart below to construct a product code.

PS75 10 4MNZ C H XX XXXX

Pressure Range Code

Insert Pressure Range Code from table below

Pressure Fitting¹

<i>12L14 Zinc Plated Steel</i>	<i>316 Stainless Steel (housing also 316SS)</i>
2MNZ 1/8" NPTM	4MNS 1/4" NPTM
4MNZ 1/4" NPTM	4MGS 1/4" BSPM
4FNZ 1/4" NPTF	4FGS 1/4" BSPF
4MGZ 1/4" BSPM	6MSS 9/16"-18 SAE Male
4FGZ 1/4" BSPF	
4MSZ 7/16"-20 SAE Male	
6MSZ 9/16"-18 SAE Male	
4SSZ 7/16"-20 SAE Male Swivel	

Circuit

A SPST/NO; **B** SPST/NC; **C** SPDT;
AA DPST/NO2; **BB** DPST/NC2; **CC** DPDT²

Electrical Termination

FLXX Flying Leads³; **ELXX** 1/2" NPT Male Conduit w/Flying Leads⁴;
H DIN 43650A Male Half Only⁵; **HR** Right Angle DIN 43650A Male Half Only⁵;
HC DIN 43650A 9mm Cable Clamp⁵;
HCR Right Angle DIN 43650A 9mm Cable Clamp⁵;
HN DIN 43650A with 1/2" Female NPT Conduit⁵;
HNR Right Angle DIN 43650A with 1/2" Female NPT Conduit⁵;

Options

V Viton® Diaphragm; **N** Neoprene Diaphragm; **E** EPDM Diaphragm;
G Gold Contacts (for loads less than 12 mA @ 12 VDC);
RD Reduced Differential (50% reduction typical); **OXY** Oxygen Cleaned⁶;
R Restrictor (low damping coefficient) Brass;
SR Spiral Restrictor (high damping coefficient) 12L14 Steel w/Black Oxide Finish;
WF Weather Pack Connector, Female; **WM** Weather Pack Connector, Male;
DE Deutsch Connector, Male, DT04 Series

Fixed Set Point (optional)

- A. Specify set point **FS** (in BAR or PSI, see example)⁷ _____
 B. Set Point Actuation _____

R on Rising Pressure; **F** on Falling Pressure

Example: **FS1BARF** for 1 BAR Falling or **FS20PSIR** for 20 PSI Rising

Notes:

- Manifold mounts available. Consult factory.
- Requires **FL** or **EL** electrical termination.
- 18" is standard. Specify lead length in inches (max. 48"). e.g. **FL18** or **FL30**.
- 18" is standard. Specify cable length in inches (max. 48"). e.g. **EL18** or **EL30**.
- DIN connectors require **C** SPDT circuit.
- Requires stainless steel pressure fitting.
- Set Point must be within Pressure Range selected in Step 1 above.

Pressure Range Table

Pressure Range Code	Pressure Range	Average Dead Band	Proof Pressure
10	0.35-1.7 bar (5-25 psi)	0.25-0.40 bar (2-4 psi)	35 bar (500 psi)
20	1.0-5.2 bar (15-75 psi)	0.35-0.65 bar (5-10 psi)	600 bar (9000 psi)
30	3.5-10.3 bar (50-150 psi)	1.3-2.6 bar (20-40 psi)	600 bar (9000 psi)
40	10.3-44.8 bar (150-650 psi)	2.6-5.7 bar (40-85 psi)	600 bar (9000 psi)
50	34.5-120.7 bar (500-1750 psi)	8-15 bar (120-220 psi)	600 bar (9000 psi)
60	69.0-241.3 bar (1000-3500 psi)	21-35 bar (300-500 psi)	600 bar (9000 psi)
70	172.4-413.7 bar (2500-6000 psi)	21-35 bar (300-500 psi)	600 bar (9000 psi)

PS77 – Economical Industrial Pressure Switch

- ▶ 0.35 to 413 bar (5 to 6000 psi) *formerly PS-K series*
- ▶ Up to 20 amp switching capabilities
- ▶ Wear disc design for longer life
- ▶ Adjustable deadband on 20 amp models

Gems PS77 Series pressure switches incorporate a wear disc and cushioning ring that provide resistance to pressure surges. The industrial enclosure houses either an SPDT 20 Amp switch featuring a dead band adjustment or a DPDT 10 amp switch. The switches use a piston/diaphragm design, which combines the high proof pressure of piston technology with the sensitivity of diaphragm designs. The switches can be field or factory adjusted.

Specifications

Operating Temperature	-40°C to +80°C (-40°F to +180°F)
Switch	20 Amp @ 240 VAC (-C circuit) 10 Amp @ 250 VAC (-CC, -Z, -ZZ circuits)
Repeatability	2% of Highest Set Point @ 20°C (70°F)
Wetted Parts	
Diaphragm	Nitrile (Optional Viton®, Neoprene or EPDM)
Fitting	Zinc Plated Steel (Optional 316 SS)
Electrical Termination	DIN 43650A or 1/2" NPTF Conduit; Plastic Case IP65
Proof Pressure	600 bar (9000 psi)
Approvals	CE
Weight, Approximate	0.45 kg (1.0 lbs.)



Dimensions

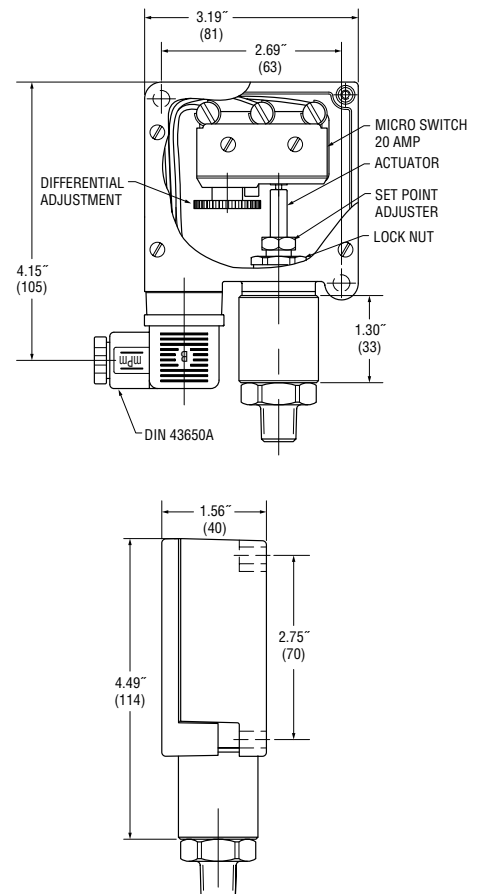

Wiring

	DIN
Common	#1
N.C.	#2
N.O.	#3

How to Order

Use the **Bold** characters from the chart below to construct a product code.

PS77 10 4MNZ C H XX XXXX

Pressure Range Code

Insert Pressure Range Code from table below

Pressure Fitting

<i>12L14 Zinc Plated Steel</i>	<i>316 Stainless Steel (housing also 316SS)</i>
2MNZ 1/8" NPTM	4MNS 1/4" NPTM
4MNZ 1/4" NPTM	4MGS 1/4" BSPM
4FNZ 1/4" NPTF	4FGS 1/4" BSPF
4MGZ 1/4" BSPM	6MSS 9/16"-18 SAE Male
4FGZ 1/4" BSPF	
4MSZ 7/16"-20 SAE Male	
6MSZ 9/16"-18 SAE Male	
4SSZ 7/16"-20 SAE Male Swivel	

Circuit

C SPDT; **CC** DPDT; **Z** SPDT-DB; **ZZ** DPDT-DB

Electrical Termination

ELXX 1/2" NPT Male Conduit w/Flying Leads¹;
H DIN 43650A Male Half Only²; **HC** DIN 43650A 9mm Cable Clamp²;
HN DIN 43650A with 1/2" Female NPT Conduit²;

Options

V Viton® Diaphragm; **N** Neoprene Diaphragm; **E** EPDM Diaphragm;
G Gold Contacts (for loads less than 12 mA @ 12 VDC); **OXY** Oxygen Cleaned³;
R Restrictor (low damping coefficient) Brass;
SR Spiral Restrictor (high damping coefficient) 12L14 Steel w/Black Oxide Finish

Fixed Set Point (optional)

A. Specify set point **FS** (in BAR or PSI, see example)⁴ _____
 B. Set Point Actuation _____

R on Rising Pressure; **F** on Falling Pressure

Example: **FS1BARF** for 1 BAR Falling or **FS20PSIR** for 20 PSI Rising

Notes:

1. 18" is standard. Specify lead length in inches (max. 48"). e.g. **EL18** or **EL30**.
2. DIN connectors require **C** SPDT circuit.
3. Requires stainless steel pressure fitting.
4. Set Point must be within Pressure Range selected in Step 1 above.

Pressure Range Table

Pressure Range Code	Pressure Range	Adjustable Dead Band	Proof Pressure
10	0.35-1.7 bar (5-25 psi)	0.17-0.43 bar (3-6 psi)	35 bar (500 psi)
20	1.0-5.2 bar (15-75 psi)	0.5-1.25 bar (8-19 psi)	600 bar (9000 psi)
30	3.5-10.3 bar (50-150 psi)	1.0-2.5 bar (15-37 psi)	600 bar (9000 psi)
40	10.3-44.8 bar (150-650 psi)	4.5-11 bar (65-160 psi)	600 bar (9000 psi)
50	34.5-120.7 bar (500-1750 psi)	12-30 bar (175-430 psi)	600 bar (9000 psi)
60	69.0-241.3 bar (1000-3500 psi)	24-60 bar (300-875 psi)	600 bar (9000 psi)
70	172.4-413.7 bar (2500-6000 psi)	42-105 bar (600-1500 psi)	600 bar (9000 psi)

PS81 – Ultra-Long Life Vacuum Switches

- ▶ 25 to 508 mbar (0.75" to 15" Hg)
- ▶ Sensitive diaphragm for lower set points
- ▶ Factory fixed or adjustable set points
- ▶ DPDT versions available

For low vacuum applications, the longevity of our PS81 Series is hard to beat. A life expectancy of 1 million cycles means long-term reliability. Their brass housing and choice of four diaphragm materials ensures chemical compatibility with your system. PS81 series switches have a field adjustable set point or can be factory set.

Specifications

Operating Temperature	-40°C to +80°C (-40°F to +180°F)
Switch*	5 Amp @ 24 VDC and 250 VAC 1 Amp @ 24 VDC (-G option)
Repeatability	±2% of Full Set Point Range at 20°C (70°F)
Wetted Parts	
Diaphragm	Nitrile standard (optional EPDM, Viton® or Kapton®)
Fitting	Brass
Housing	Brass
Spring	Stainless Steel
Spring Guide	Dolrin
Electrical Termination	DIN 43650A IP65; Terminals IP00; Flying Leads IP65; IP option IP66
Proof Pressure	10 bar (150 psi)
Approvals	CE, UL Approved units available
Weight, Approximate	0.14 kg (0.31 lbs.)

*Gold contacts (option G) may be required for less than 12 VDC and 20 mA.

How to Order

Use the **Bold** characters from the chart below right to construct a product code.

PS81 10 4MNB C H XX XXXX

Pressure Range Code _____
Insert Pressure Range Code from table below

Pressure Fitting _____
2MNB 1/8" NPTM Brass; **4MNB** 1/4" NPTM Brass;
2FNB 1/8" NPTF Brass; **4MGB** 1/4" BSPM Brass;
4MSB 7/16"-20 SAE Male, Brass;
6MSB 9/16"-18 SAE Male, Brass

Circuit _____
A SPST/NO; **B** SPST/NC; **C** SPDT; (at zero pressure (gauge))
AA DPST/NO; **BB** DPST/NC; **CC** DPDT

Electrical Termination _____
FLXX Flying Leads¹; **ELXX** 1/2" NPT Male Conduit w/Flying Leads²;
H DIN 43650A Male Half Only³; **HC** DIN 43650A 9mm Cable Clamp³;
HN DIN 43650A with 1/2" Female NPT Conduit³

Options _____
V Viton® Diaphragm; **E** EPDM Diaphragm; **K** Kapton® Diaphragm;
G Gold Contacts (for loads less than 12 mA @ 12 VDC); **OXY** Oxygen Cleaned;
IP Ingress Protection⁴

Fixed Set Point (optional) _____
A. Specify set point **FS** (in Inches Hg or mBAR, see example)⁵
B. Set Point Actuation _____
R on Rising Vacuum; **F** on Falling Vacuum
Example: **FS100MBAF** for 100 mBAR Falling or **FS2INHGR** for 2" Hg Rising

Notes:

- 18" is standard. Specify lead length in inches (max. 48"). e.g. **FL18** or **FL30**.
- 18" is standard. Specify cable length in inches (max. 48"). e.g. **EL18** or **EL30**.
- DIN connectors require **C** SPDT circuit.
- Ingress Protection is available only with **FL** Electrical Termination and requires Fixed Set Point **FS**.
- Set Point must be within Pressure Range selected in Step 1 above.



Dimensions

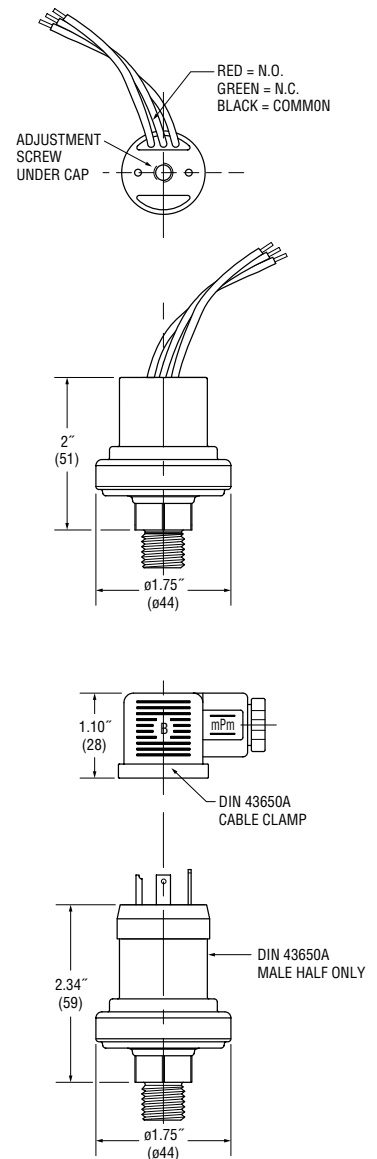

Pressure Range Table

Pressure Range Code	Pressure Range	Average Dead Band
10	25.4 - 169.3 mbar (0.75-5"Hg)	6 - 17 mbar (0.2-0.5"Hg)
20	135.5-508 mbar (4-15"Hg)	10 - 24 mbar (0.3-0.7"Hg)

PS82 – Economical Miniature Vacuum Switches

▶ 169 to 1016 mbar (5" to 30" Hg) formerly PS-EV series

These miniature vacuum switches, based on our proven PS71 series, are designed for demanding applications where space and/or price are strong concerns.

Specifications

Operating Temperature	-40°C to +80°C (-40°F to +180°F)
Switch*	5 Amp at 12/24 VDC and 125/250 VAC; 1 Amp with gold contacts (option G)
Repeatability	±2% of Full Set Point Range @ 20°C (70°F)
Wetted Parts	
Diaphragm Material	Nitrile standard (optional EPDM, Viton® and Neoprene)
Fitting	Brass (optional 316 Stainless Steel)
Spring	316 Stainless Steel
Electrical Termination	DIN 43650A IP65; Male Conduit with Flying Leads IP00; Flying Leads IP65; IP option IP66
Proof Pressure	35 bar (500 psi)
Approvals	CE
Weight, Approximate	0.25 kg (0.5 lbs.)

*Gold contacts (option G) may be required for less than 12 VDC and 20 mA.

Viton® is a registered trademark of Dupont.

How to Order

Use the **Bold** characters from the chart below to construct a product code.

PS82 10 -4MNB -C -H -XX -XXXX

Pressure Range Code

Insert Pressure Range Code from table below right

Pressure Fitting¹

Brass

316 Stainless Steel

2MNB 1/8" NPTM

2MNS 1/8" NPTM

4MNB 1/4" NPTM

4MNS 1/4" NPTM

2MGB 1/8" BSPM

4MGS 1/4" BSPM

4MGB 1/4" BSPM

4MSB 7/16"-20 SAE Male

6MSB 9/16"-18 SAE Male

Circuit

A SPST/NO; **B** SPST/NC; **C** SPDT; (at zero pressure (gauge))

Electrical Termination

FLXX Flying Leads²; **FLSXX** Flying Leads w/PVC Shrink Tubing²;

ELXX 1/2" NPT Male Conduit w/Flying Leads³; **CABXX** 18 AWG PVC Cable⁴;

H DIN 43650A Male Half Only⁵; **HR** Right Angle DIN 43650A Male Half Only⁵;

HC DIN 43650A 9mm Cable Clamp⁵;

HCR Right Angle DIN 43650A 9mm Cable Clamp⁵;

HN DIN 43650A with 1/2" Female NPT Conduit⁵;

HNR Right Angle DIN 43650A with 1/2" Female NPT Conduit⁵;

HM Micro (9.4mm Spacing) DIN Style Male Half Only⁵

Options

V Viton® Diaphragm; **N** Neoprene Diaphragm; **E** EPDM Diaphragm;

G Gold Contacts (for loads less than 12 mA @ 12 VDC)

RD Reduced Differential (50% reduction typical); **IP** Ingress Protection⁶;

OXY Oxygen Cleaned; **WF** Weather Pack Connector, Female;

WM Weather Pack Connector, Male; **DE** Deutsch Connector, Male, DT04 Series

Fixed Set Point (optional)

A. Specify set point **FS** (in mBAR or Inches Hg, see example)⁷

B. Set Point Actuation

R on Rising Vacuum; **F** on Falling Vacuum

Example: **FS300MBARF** for 300 mBAR Falling or **FS10INHGR** for 10" Hg Rising



Dimensions

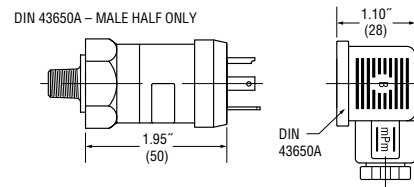
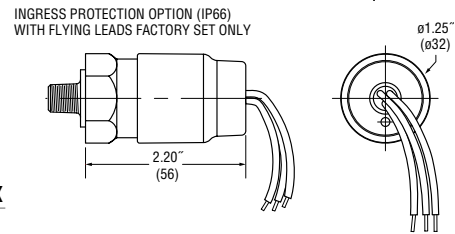
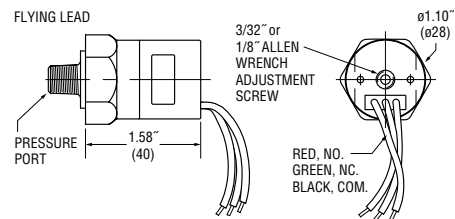

Pressure Range Table

Pressure Range Code	Pressure Range	Average Dead Band
10	169.3 - 508.0 mbar (5 - 15" Hg)	100 - 150 mbar (3 - 5" Hg)
20	406.4 - 1016.0 mbar (12 - 30" Hg)	100 - 270 mbar (3 - 9" Hg)

Notes:

- Other connectors available. Consult factory.
- 18" is standard. Specify lead length in inches (max. 48"). e.g. **FL18** or **FLS30**.
- 18" is standard. Specify cable length in inches (max. 48"). e.g. **EL18** or **EL30**.
- 36" is minimum. Specify cable length in inches. e.g. **CAB36** or **CAB120**.
- DIN connectors require **C** SPDT circuit.
- Ingress Protection is available only with **FL**, **FLS** or **CAB** Electrical Termination choices. Ingress Protection requires Fixed Set Point **FS**.
- Set Point must be within Pressure Range selected in Step 1 above.

PS83 – OEM Subminiature Vacuum Switch

▶ 169 to 1016 mbar (5" to 30" Hg) formerly PS-J series

This compact vacuum switch is designed for OEM applications. Metal blade contacts in lieu of microswitches make this a very economical switch. The PS83 series features Teflon®-coated Kapton® diaphragms. Kapton® polyimide maintains excellent physical properties over a wide temperature range, while the Teflon® coating offers superb chemical resistance.

Specifications

Operating Temperature	-40°C to +93°C (-40°F to +200°F)
Switch*	100 VA Max.; 42 V Maximum Voltage
Repeatability	±5% of Full Set Point Range @ 20°C (70°F) ambient temp.
Wetted Parts	
Diaphragm	Teflon®-coated Kapton®
Housing	Brass (optional 316 SS)
Electrical Termination	Exposed Terminals IP00; Flying Leads IP00; IP option IP65
Proof Pressure	10 bar (150 psi)
Approvals	CE (UL Approved units available)
Weight, Approximate	0.06 kg (0.14 lbs.)

*Gold contacts (option G) may be required for less than 12 VDC and 20 mA.
Teflon® and Kapton® are registered trademarks of Dupont.

How to Order

Use the **Bold** characters from the chart below to construct a product code.

PS83 10 4MNB A SP XX XXXX

Pressure Range Code _____
Insert Pressure Range Code from table below

Pressure Fitting¹ _____

<i>Brass</i>	<i>316 Stainless Steel</i>
2MNB 1/8" NPTM	2MNS 1/8" NPTM
4MNB 1/4" NPTM	4MNS 1/4" NPTM
2MGB 1/8" BSPM	2MGS 1/8" BSPM
4MGB 1/4" BSPM	4MGS 1/4" BSPM
8MGB 1/2" BSPM	4MSS 7/16"-20 SAE Male
M10B M10 x 1.0 Straight	6MSS 9/16"-18 SAE Male
M12B M12 x 1.5 Straight	
4MSB 7/16"-20 SAE Male	
6MSB 9/16"-18 SAE Male	

Circuit _____
A SPST/NO; **B** SPST/NC (at zero pressure (gauge))

Electrical Termination _____
SP Spade Terminals (standard); **TS** Terminal Screws;
FLXX Flying Leads²; **FLSXX** Flying Leads w/PVC Shrink Tubing²

Options _____
G Gold Contacts (for loads less than 12 mA @ 12 VDC); **IP** Ingress Protection³;
OXY Oxygen Cleaned; **RB** Rubber Boot (shipped loose);
WF Weather Pack Connector, Female; **WM** Weather Pack Connector, Male;
DE Deutsch Connector, Male, DT04 Series

Fixed Set Point (optional) _____
A. Specify set point **FS** (in mBAR or Inches Hg, see example)⁴ _____
B. Set Point Actuation _____
R on Rising Vacuum; **F** on Falling Vacuum
Example: **FS300MBAF** for 300 mBAR Falling or **FS10INHGR** for 10" Hg Rising



Dimensions

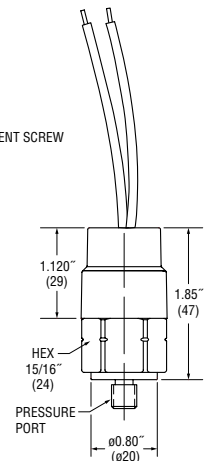
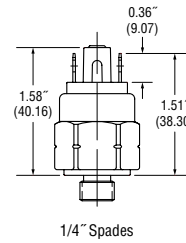
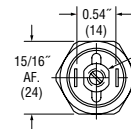

1/4" Spades

Flying Leads with IP option

Pressure Range Table

Pressure Range Code	Pressure Range	Average Dead Band
10	169.3-508.0 mbar (5 - 15" Hg)	Less than 10% of full set point range
20	406.4-1016.0 mbar (12 - 30" Hg)	

Notes:

- Other connectors available. Consult factory.
- 18" is standard. Specify lead length in inches (max. 48"). e.g. **FL18** or **FLS30**.
- Ingress Protection is available only with **FL** or **FLS** Electrical Termination.
- Set Point must be within Pressure Range selected in Step 1 above.

PS91 – Compact Differential Switch

- ▶ .3 to 1.7 bar (5 to 25 psi)
- ▶ Unaffected by static pressure
- ▶ Robust packaging for harsh applications

The PS91 is a differential pressure switch that is not affected by changes in static pressure (common line pressure). The PS91 is designed for a unique manifold, or supplied with two 1/8" NPT female ports for more general purpose applications. The switch can be adjusted via a central screw on top of the unit. The unit is supplied with a mini-DIN connector in keeping with the compact packaging.

Specifications

Operating Temperature	-40°C to +80°C (-40°F to +180°F)
Switch*	5 Amp @ 24 VDC and 250 VAC; 0.5 Amp @ 24 VDC
Repeatability	±2% of Full Set Point Range @ 20°C (70°F)
Wetted Parts	
Diaphragm	Nitrile standard (optional EPDM and Viton®)
Fitting	Black Anodized Aluminum
Housing	30% Glass Filled Nylon; Buna-N O-rings
Electrical Termination	DIN 43650C IP65; Terminals IP00
Proof Pressure	100 bar (1500 psi)
Approvals	CE
Weight, Approximate	0.045 kg (0.10 lbs.)



Dimensions

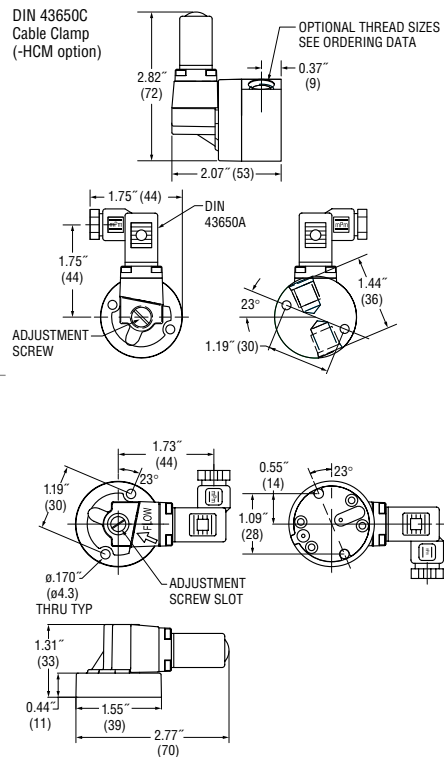

*Gold contacts (option G) may be required for less than 12 VDC and 20 mA.

How to Order

Use the **Bold** characters from the chart below to construct a product code.

PS91 10 4FSA C HM XX XXXX

Pressure Range Code _____
Insert Pressure Range Code from table below

Pressure Fitting _____
2FNA 1/8" NPTF Aluminum;
4FSA 7/16"-20 SAE Female, Aluminum;
30MA Manifold Mount, (2) 4.3 mm Dia. Holes, 30.2 mm Dia. B.C., Anodized Black Aluminum

Circuit _____
C SPDT

Electrical Termination _____
HM DIN 43650C Male Half Only (standard);
HCM DIN 43650C 7 mm Cable Clamp

Options _____
V Viton® Diaphragm; **E** EPDM Diaphragm

Fixed Set Point (optional) _____
A. Specify set point **FS** (in BAR or PSI, see example)* _____
B. Set Point Actuation _____
R on Rising Pressure; **F** on Falling Pressure
Example: **FS1BARF** for 1 BAR Falling or **FS10PSIR** for 10 PSI Rising

Note:

- Set Point must be within Pressure Range selected in Step 1 above.

Pressure Range Table

Pressure Range Code	Pressure Range	Average Dead Band
10	0.35 - 1.0 bar (5 - 15 psid)	0.15-0.3 bar (2-5 psi)
20	0.8 - 1.7 bar (12 - 25 psid)	0.25-0.5 bar (4-7 psi)

PS93 – General Purpose Differential Pressure Switch

- ▶ .7 to 3 bar (10 to 45 psi) *formerly PS-D series*
- ▶ Compact construction
- ▶ Can be mounted in tight spaces
- ▶ Rugged housing

The PS93 Series compact design enables them to be mounted in tight spaces. The switches use a piston/diaphragm design which incorporates the high proof pressure of piston technology with the sensitivity of a diaphragm design. The PS93 series switches may be field or factory adjusted via a hex screw inside the low port, protecting them against unauthorized tampering.

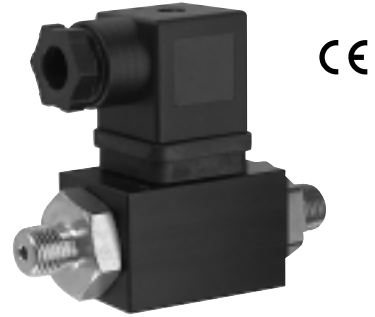

Specifications

Operating Temperature

Buna-N	-20°C to +80°C (-4°F to +176°F)
EPDM1	-40°C to +80°C (-40°F to +176°F)
Viton®1	+0°C to +80°C (+32°F to +176°F)

Switch²	5 Amp SPDT @ 240 VAC and 24 VDC; 0.5 Amp @ 24 VDC (-G option)
---------------------------	--

Repeatability	±2% of highest set point @ 20°C (68°F)
----------------------	--

Wetted Parts

Diaphragm	Buna-N (optional EPDM, Viton® and Neoprene)
Fitting	Zinc-plated steel (optional Brass or 316 Stainless Steel)

Electrical Termination	DIN 43650A (IP65)
-------------------------------	-------------------

Proof Pressure	35 bar (500 psi)
-----------------------	------------------

Approvals	CE
------------------	----

Weight, Approximate	0.35 kg (0.75 lbs.)
----------------------------	---------------------

Notes:

1. Optional
2. Gold contacts (option G) may be required for less than 12 VDC and 20 mA.

How to Order

Use the **Bold** characters from the chart below to construct a product code.

PS93	10	4MNS/4MNS	C	HM	XX	XXXX
Pressure Range Code	Insert Pressure Range Code from table below right					
Pressure Fitting	High Port/Low Port					
	12L14 Zinc Plated Steel	Brass				
	2MNZ 1/8" NPTM;	4MNB 1/4" NPTM;				
	2MGZ 1/8" BSPM;	4MGB 1/4" BSPM				
	4MNZ 1/4" NPTM;					
	4MGZ 1/4" BSPM;					
	4FNZ 1/4" NPTF;					
	4MSZ 7/16"-20 SAE Male					
	316 Stainless Steel	316 Stainless Steel				
	4MNS 1/4" NPTM	4MNS 1/4" NPTM				

Circuit

C SPDT

Electrical Termination

H DIN 43650A Male Half Only (standard); **HC** DIN 43650A 9mm Cable Clamp;
HN DIN 43650A with 1/2" Female NPT Conduit

Options

V Viton® Diaphragm; **E** EPDM Diaphragm; **N** Neoprene Diaphragm;

G Gold Contacts (for loads less than 12 mA @ 12 VDC)

Fixed Set Point (optional)

- Specify set point **FS** (in BAR or PSI, see example)¹
- Set Point Actuation

R on Rising Pressure; **F** on Falling Pressure

Example: **FS1BARF** for 1 BAR Falling or **FS10PSIR** for 10 PSI Rising

Note:

1. Set Point must be within Pressure Range selected in Step 1 above.

Dimensions

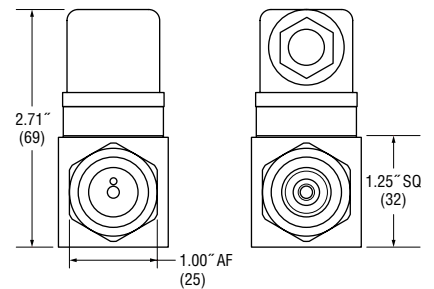
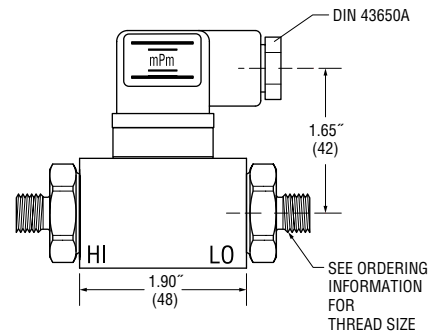
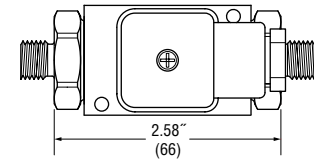

Pressure Range Table

Pressure Range Code	Pressure Range	Average Dead Band
10	0.7 - 1.7 bar (10 - 25 psi)	0.2 - 0.4 bar (3 - 8 psi)
20	1.4 - 3.1 bar (20 - 45 psi)	0.35 - 1 bar (5 - 15 psi)

PS96/97 – Inline Pressure Switch

- ▶ 2 to 10 bar (30 to 150 psi)
- ▶ Visual adjustment
- ▶ Robust packaging for harsh applications
- ▶ PS97 Unique Manifold Mount

The PS96 is a compact switch featuring a simple field adjustment. The PS97 has a unique 2 bolt manifold mount. The mating flat surface only needs to accept 2 mounting screws to secure the pressure fitting in place. The single turn adjustment has an indicating scale on it for quick adjustments in the field. The miniature DIN standard "C" utilizes 8 mm spacing between contact pins. Its all-metal enclosure and small size make it an ideal choice for mounting in tight areas.

Specifications

Operating Temperature	-40°C to +80°C (-40°F to +180°F)
Switch*	5 Amp @ 24 VDC and 250 VAC; 0.5 Amp @ 24 VDC
Adjustment Range	2-10 bar (30-150 psi)
Repeatability	±2% of Full Set Point Range @ 20°C (70°F)
Wetted Parts	
Diaphragm	Nitrile
Fitting	Brass (PS97 Aluminium, Anodized Black, 'O' Ring)
Electrical Termination	DIN 43650C IP65
Average Deadband	.8-1.70 bar (12-25 psi)
Proof Pressure	100 bar (1500 psi)
Approvals	CE
Weight, Approximate	0.06 kg (0.13 lbs.)

How to Order

Use the **Bold** characters from the chart below to construct a product code.

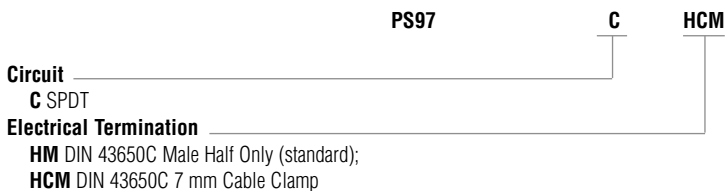
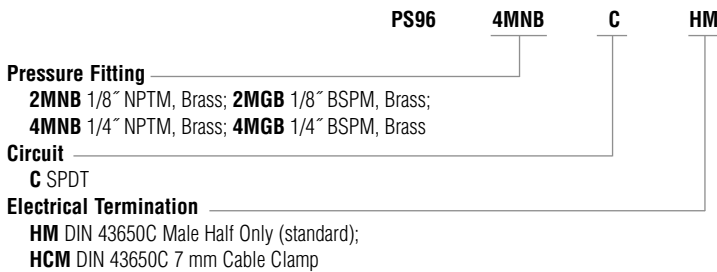

PS96



PS97



Dimensions

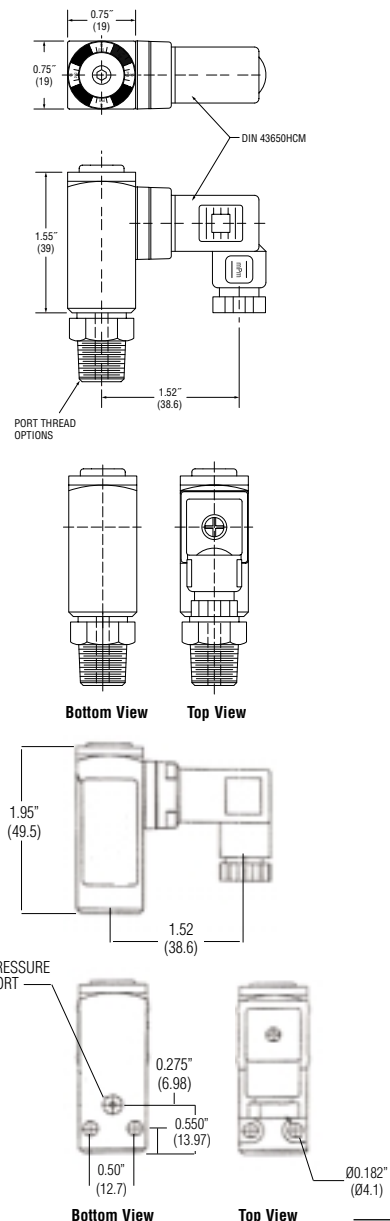

PS98 - Solid State Pressure Switch

- ▶ 0 to 400 bar and 0 to 6000 psi
- ▶ Highly resistant to shock and vibration
- ▶ Ideal for off-highway, mobile, demanding applications
- ▶ No moving parts
- ▶ Long cycle life

Answering the demand for solid-state switches, Gems proudly offers the PS98. Built from our proven CVD and ASIC design, the PS98 Solid State pressure switch offers greater accuracy in rough environments. This switch is an ideal alternative to electromechanical types when cycles exceed 50 cycles/minute and broad frequency response is needed. In addition to a modular design, a host of pressure ports and electrical connections are available. Switch and switch-back points are factory set per customer specification.

Specifications

Operating Temperature	-40°C to 125°C (-40°F to 260°F)
Switch	Relay or Transistor
Repeatability	.25% of Full Set point range @ 20°C (70°F)
Wetted Parts	
Diaphragm	17-4PH Stainless Steel
Fitting	316 Stainless Steel
Electrical Termination	
	DIN "G" IP65 10-6 MIL CONN "C" IP65 Submersible Cable "M" IP68
Supply Voltage (Vs)	12 to 32Vdc
Vibration	70g, peak to peak sinusoidal, 5 to 2000 Hz (Random Vibration: 20 to 2000 Hz @ appx. 20g Peak per MIL-STD-810E Method 514.4)
Acceleration	100g steady acceleration in any direction 0.032% FS/g for 1 bar (15 psi) range decreasing logarithmically to 0.0007% FS/g for 400 bar (6000 psi) range.
Shock Method 516.4 Procedure 1	20g, 11 ms, per MIL-STD-810E
Deadband	See How to Order
Proof Pressure	2X Full Scale
Approvals	CE (limits switch voltage to 42 VDC)
Weight, Approx.	0.45 kg (1.0 lbs)

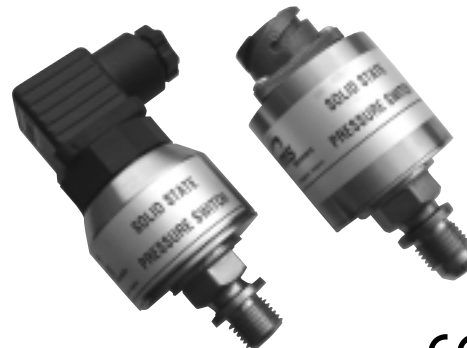

Dimensions

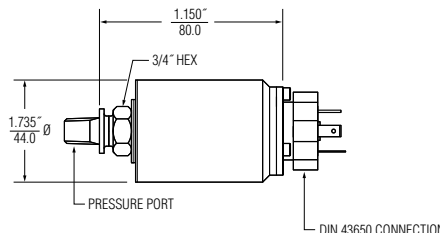
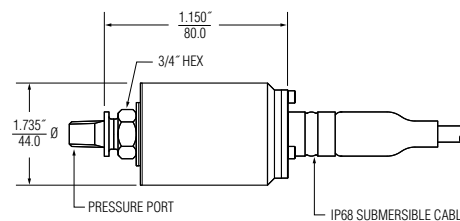

How to Order

Use the **bold** characters from the chart below to construct a product code

PS98 R G G15 02 G A 150 125

Output _____
R Relay; **T** Transistor

Pressure Datum _____
A Absolute (up to 25 bar) **G** Gauge

Pressure Range _____
 Insert Pressure Range Code from table below right

Pressure Port _____
08 1/8-27 NPT External; **02** 1/4-18 NPT External;
0J 1/4 NPT External w/snubber; **0E** 1/4 NPT Internal;
0H 1/2-14 NPT External; **04** 7/16-20 External (SAE #4, J514);
1P 9/16-18 External (SAE #6, J1926-2);
IJ 7/16-20 External (SAE #4, J1926-2);
09 G1/8 Internal; **01** G1/4 External; **0A** R1/4 External

Electrical Termination _____
G Large DIN (only with Transistor);
MXXX IP68 Cable (Specify length in meters; e.g. **M012**);
C 6-Pin Connector

Circuit _____
A N.O.; **B** N.C.; **C** SPDT (only with Relay)

Factory Set Point' _____

Re-Set Point' _____

Pressure Range Table

Pressure Range Code	Pressure Range (bar)	Pressure Range Code	Pressure Range (psi)
A10	0-1	F15	0-15
A16	0-1.6	F30	0-30
A25	0-2.5	F60	0-60
A40	0-4	G10	0-100
A60	0-6	G15	0-150
B10	0-10	G20	0-200
B16	0-16	G30	0-300
B25	0-25	G50	0-500
B40	0-40	G60	0-600
B60	0-60	H10	0-1000
C10	0-100	H15	0-1500
C16	0-160	H20	0-2000
C25	0-250	H30	0-3000
C40	0-400	H40	0-4000
		H50	0-5000
		H60	0-6000

Note:

1. Set Points must be within Pressure Range selected in Step 3 above.

PS-B Series – High Performance Pressure Switch

- ▶ Vacuum and Pressure Ranges
- ▶ 0.5% Repeatability
- ▶ Compact Design

Gems PS-B Series are economically designed pressure switches that use high-quality materials and workmanship to provide the very best service. The PS-B Series is available in a diaphragm/piston combination design or a traditional piston design. Both offer very high operating and proof pressure specifications. These high proof pressures greatly reduce the chance that pressure spikes and surges will damage the unit.

Specifications

Process/Ambient Temperature	-40°C to +80°C (-40°F to +176°F)
Switch	5 Amp SPDT@240 VAC, 5 Amp@30 VDC,
Approvals	CE, Microswitch is UL and CSA Recognised
Repeatability	0.5% of Highest Set Point @ 20°C (68°F)
Wetted Parts (other materials available)	
Diaphragm	Buna-N
O-Ring	Buna-N
Fitting	Brass or Stainless Steel
Enclosure	IP66 (Nema 4X) Anodized Aluminum
Electrical Termination	IP65, DIN 43650 Connector
Pressure Port	G1/4 Female or 1/4" NPT
Weight, Approximate	0.4 kg (1 lbs.)

How to Order

Use the **bold** characters from the chart below to construct a product code

SELECT PS **B2** P504H S1N B1 BL G B

B2 Series _____

Insert **Range Code** From Table Below _____

Pressure Port (*) _____

S1 316 ss 1/4" female; S2 316 ss 1/2" female; S7 316 ss 1/2" male;
 B1 brass 1/4" female;
 Last character **N** for NPT thread or **B** for BSP thread

Diaphragm/O-Ring Material _____

B1 buna-n/buna-n; P1 PTFE/buna-n; P2 PTFE/VITON; E6 EPDM/EPDM;
 S2 316 ss/Viton®-A ; V2 Viton®-A/Viton®-A

Microswitch _____

BL standard; BG gold-plated switch

Options _____

M vacuum protection plate for pressure switches; B oxygen cleaned

Note:

(*) Brass connections are on fluid power switches



Dimensions

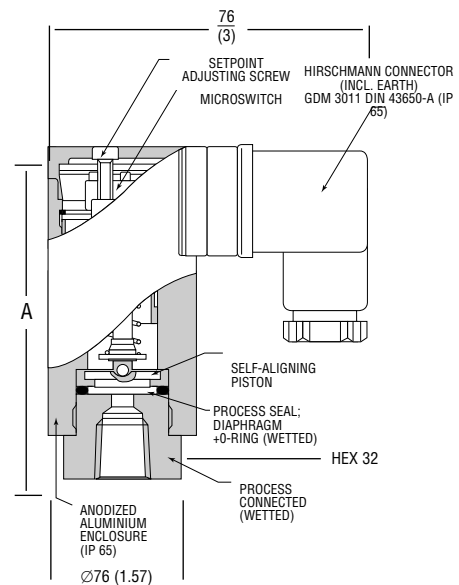

Type	A
Pressure Switch	92mm (3.62")
Vacuum Switch	107mm (4.21")
Fluid Power	100mm (3.94")

Type	Pressure Port	Range Range Code	Adjustable Range	Typical Deadband Midrange	Operating Pressure Max.	Proof Pressure
Pressure	316 Stainless Steel	-P504H	0.3-4.5 bar (4-65 psi)	0.08 bar (1.2 psi)	200 bar (3000 psi)	600 bar (8500 psi)
		-P508H	1-25 bar (15-360 psi)	0.48 bar (7 psi)	200 bar (3000 psi)	600 bar (8500 psi)
		-P708H	3-85 bar (45-1230 psi)	2 bar (30 psi)	200 bar (3000 psi)	600 bar (8500 psi)
		-P808H	5-170 bar (75-2500 psi)	5 bar (75 psi)	400 bar (5800 psi)	600 bar (8500 psi)
		-P908H	10-300 bar (150-4300 psi)	15 bar (215 psi)	400 bar (5800 psi)	600 bar (8500 psi)
Fluid* Power	Brass	-P908F	20-300 bar (300-4300 psi)	15 bar (215 psi)	850 bar (9000 psi)	700 bar (10000 psi)
		-P918F	30-540 bar (450-7500 psi)	20 bar (290 psi)	650 bar (9000 psi)	700 bar (10000 psi)
Vacuum	316 Stainless Steel	-V506H	-1 to 6 bar (30" Hg-85 psi)	0.12 bar (2psi)	200 bar (3000 psi)	600 bar (8500 psi)

PS-C Series – High Performance Industrial Switch

- ▶ Vacuum, Differential & Pressure Switches
- ▶ Vacuum to 540 bar (7500 PSI) Pressure Range
- A Excellent 0.2% Repeatability

Gems PS-C Series pressure switches have been painstakingly designed to provide a very easy end user interface and reliable service. Details like stainless steel mounting brackets for the microswitch; self-locking adjusting nut; internal stainless steel pistons and spring; and baked-on enclosure finishes highlight these design efforts. The PS-C uses either a diaphragm/piston combination design or a traditional piston design.

Specifications

Process/Ambient Temperature	-40 to 80C (-40 to +176F)
Switch	15 Amp SPDT@240 VAC, 0.5 Amp@28 VDC, (Ranges 200 mbar), use a 10 Amp@240 VAC / 0.5 Amp@28 VDC)
Approvals	CE, Microswitch is UL & CSA Recognised
Repeatability	0.2% of Highest Set Point @ 20°C (68°F)
Wetted Parts (other materials available)	
Diaphragm	Buna-N
O-Ring	Buna-N
Fitting	Aluminum or Stainless Steel
Enclosure	Aluminum or Stainless Steel Enclosure IP66 (Nema 4X) Aluminum With Baked-On Enamel Coating
Adjustable Dead Band Option	4 Times Listed Values
Electrical Termination	PG13.5 Cable Gland or 3/4" NPT Conduit
Process Fitting	G 1/4 or 1/4" NPT
Weight, Approximate	1.5 kg (3.3 lbs.)

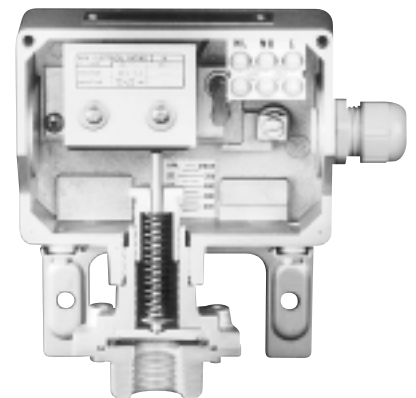

How to Order

Use the **bold** characters from the chart below to construct a product code

SELECT **PS** **C1** **P504H** **S1N** **B1** **K1** **G** **C**

Series/Enclosure _____
C1 PG13.5 cable gland; **C2** M20 x 1.5;
C3 3/4" NPTF conduit; **C8** M20 x 1.5 ss enclosure

Insert Range Code From Table _____

Pressure Port _____
 1st Character: **S** for 316 SS; **A** aluminium; **B** brass; **M** Monel®;
 2nd Character: **1** for 1/4" female fitting, **2** for 1/2" female fitting;
 3rd Character: **N** for NPT thread; **B** for bsp thread

Diaphragm/O-Ring Material _____
B1 buna-n/buna-n; **P1** PTFE/buna-n; **P4** PTFE/PTFE; **E6** EPDM/EPDM;
S2 316 ss/Viton®-A ; **V2** Viton®-A/Viton®-A

Microswitch _____
K1 standard (**L1**) standard on 301L ranges and 302L ranges; **G1** gold contacts
SL hermetically sealed; **SP** narrow adjustable deadband; **SR** wide adjustable deadband;
SE manual reset increasing; **SG** manual reset decreasing

Options _____
C cable gland; **B** oxygen cleaned; **M** vacuum protection for pressure switches;

Dimensions

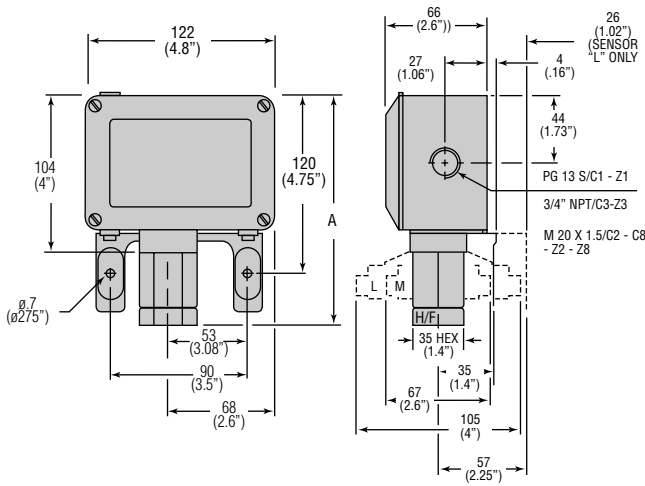

Type

Note: 1 bar = 14.5 psi

Type	Pressure Port	Range Code	Pressure Range	Max Deadband	Max Operating	Proof Pressure
			Bar	Bar	Bar	Bar
Pressure	Aluminium	-P301L ¹	2-15 mbar	1.1-1.9 mbar	30	35
		-P302L ¹	10-100 mbar	2.5-3.5 mbar	30	35
		-P304L	20-240 mbar	6-9 mbar	30	35
		-P306L	20-560 mbar	6-12 mbar	30	35
		-P308L	25-1300 mbar	7-15 mbar	30	35
		-P402M	100-400 mbar	15-20 mbar	125	140
		-P404M	100-950 mbar	15-30 mbar	125	140
		-P406M	120-2300 mbar	16-50 mbar	125	140
	-P408M	150-5400 mbar	16-90 mbar	125	140	
	316 Stainless Steel	-P502H	0.3-1.6	65-95 mbar	200	600
		-P504H	0.4-3.9	65-160 mbar	200	600
		-P506H	0.5-9.0	65-330 mbar	200	600
		-P508H	0.7-21.5	70-810 mbar	200	600
		-P708H	3-76	0.3-3.75	200	600
-P808H		4-170	0.8-9.5	400	600	
Fluid Power*	Brass	-P904F	12-55	3.5-6	650	700
		-P906F	16-130	4-8.5	650	700
		-P908F	20-300	6-12	650	700
		-P918F	30-540	15-31	650	700
Vacuum	Aluminium	** -V304L	-60/+150 mbar	4/6.5 mbar	30	35
		-V404M	-400/+400 mbar	16/25 mbar	125	140
	316 S.S.	-V506H	-1/6	80/300 mbar	200	600

* Fluid power switches are for hydraulic use and not for use on gas systems (piston design).

** Vacuum limit is -0.5 bar (15" Hg).

¹ Range only with L1 micro switch

PS-C Series – Differential Pressure Switch

- ▶ Wide Pressure Range (12 mbar to 70 bar)
- ▶ High Line Pressure (up to 200 bar)
- ▶ Wide Chemical Compatibility

The PS-C Differential Series is designed so they provide ease of installation together with reliable service. Diaphragm/piston design allows for wide pressure ranges and accuracy with good chemical compatibility. Line pressure of up to 200 bar can be used and the unit is protected against a complete line collapse in either direction.

Specifications

Process/Ambient Temperature	-40°C to +80°C (-40°F to +176°F)
Switch	15 Amp SPDT@240 VAC, 0.5 Amp@28 VDC, (Ranges 75 mbar), use a 10 Amp@240 VAC / 0.5 Amp@28 VDC)
Approvals	CE, Microswitch is UL & CSA Recognised
Repeatability	1% of Highest Set Point @ 20°C (68°F)
Wetted Parts (other materials available)	
Diaphragm	Buna-N
O-Ring	Buna-N
Fitting	Aluminum or Stainless Steel
Enclosure	Aluminum or Stainless Steel Enclosure IP66 (Nema 4X) Aluminum With Baked-On Enamel Coating
Electrical Termination	PG13.5 Cable Gland or 3/4" NPT Conduit
Process Fitting	G 1/4 or 1/4" NPT
Weight, Approximate	1.5 kg. (3.3 lbs)

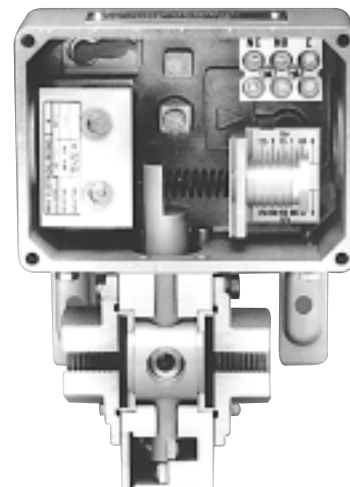

How to Order

SELECT PS C1 D506M S1N B1 K1 G C

Series/Enclosure _____
C1 PG13.5 cable gland; **C2** M20 x 1.5;
C3 3/4" NPTF conduit; **C8** M20 x 1.5 ss enclosure

Insert Range Code From Table _____

Pressure Port _____
 1st Character: **S** for 316 SS; **A** aluminium; **B** brass; **M** Monel®;
 2nd Character: **1** for 1/4" female fitting, **2** for 1/2" female fitting;
 3rd Character: **N** for NPT thread; **B** for bsp thread

Diaphragm/O-Ring Material _____
B1 buna-n/buna-n; **P1** PTFE/buna-n; **P4** PTFE/PTFE; **E6** EPDM/EPDM;
S2 316 ss/Viton®-A; **V2** Viton®-A/Viton®-A

Microswitch _____
K1 standard (**L1**) standard on 301L ranges and 302L ranges; **G1** gold contacts
SL hermetically sealed; **SP** narrow adjustable deadband

Options _____
C cable gland; **B** oxygen cleaned; **M** vacuum protection for pressure switches;

Port	Range Code	Adjustable Diff. Range	Typical Deadband	Max. Static Pressure	Max. Overrange Pressure	Proof Pressure
Aluminium	-D302L	12-75 mbar ¹	7 mbar	30 bar	30 bar	35 bar
	-D304L	22-180 mbar	8 mbar			
	-D306L	25-450mbar	11 mbar			
	-D309L	35-1250 mbar	15 mbar			
	-D402M	0.3-1.0 bar	0.15 bar	10 bar	140 bar ²	140 bar
	-D404M	0.5-2.5 bar	0.2 bar	50 bar		
	-D406M	1.0-6.0 bar	0.2 bar			
	-D408M	1.0-14.5 bar	0.2 bar	100 bar		
	-D506M	5-20 bar	0.8 bar			
	-D508M	10-50 bar	0.8 bar			
-D608M	10-70 bar	1.5 bar	140 bar			
316 Stainless Steel	-D352H	80-160 mbar	25 mbar	200 bar	200 bar ²	200 bar
	-D354H	100-500 mbar	35 mbar			
	-D356H	120-1450 mbar	50 mbar			
	-D359H	150-3450 mbar	75 mbar			

¹ Range only with "L1" micro switch.

² D ... H and D ... M can sustain full High and Low-side reversal.

Range Code 'M'

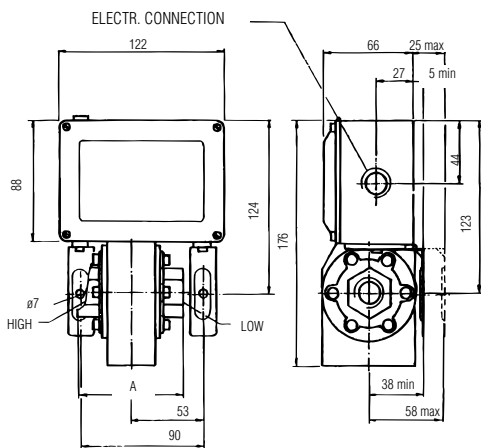

Range Code 'H'

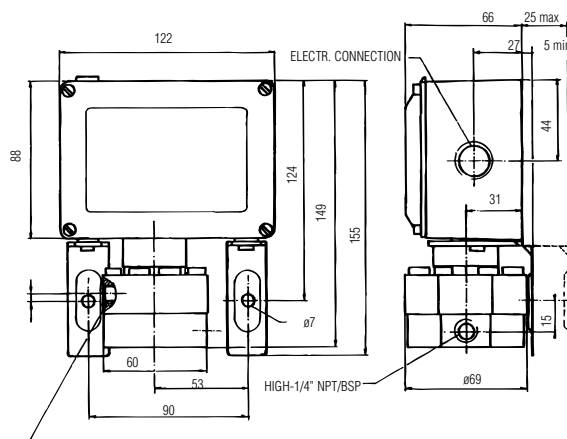

Range Code 'L'

